

LJT 23-P1 1 x 250 A

HE308 23-01

Single way 250A power circular connector

MAIN CHARACTERISTICS

- **Corrosion resistance**
olive drab cadmium-plate aluminium or electroless nickel
- **Quick positive coupling**
3 point bayonet lock system
- **Durability**
500 cycles
- **Insulation resistance at ambient under 500 Vdc > 5 000 Mohms**
- **1 size 4/0 contact**
- **Temperature range**
- 65 °C / + 175 °C
- **Contact rating**
current capability 250 A (please consult us for derating curve)

Socket contact equipped with a gold plated beryllium copper spring

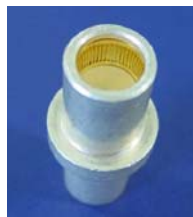

Contact		Crimp barrel		Cable sizes		
Size	Pin Contact diameter (mm)	Diameter (mm)	Depth (mm)	Cable designation *	Section (mm ²)	Outside diameter (without insulator) (mm)
2/0	12	12.1	21	CANUS 16012	75	12
2/0	12	14.6	21	CANUS 16013	100	14

* : for other cable designations, Amphenol Socapex is ready to realize pulling tests after crimping.

E122/B

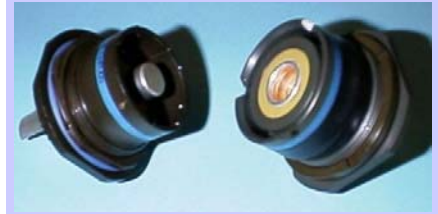

DESCRIPTION

The Amphenol Socapex power connector LJT 23-P1 (1 x 250 A) has been developed for military applications, when high power supply is required as well as EMI RFI protection for peripheral electronic devices.

LJT 23-P1 connector provides one size 2/0 power contact in a 23 shell size according to MIL-DTL-38999 Series I standard.

High performance for power supply

APPLICATIONS

- Shelters
- Firing posts
- Motor starting
- Air conditioning
- Automation

Amphenol

Application tools & process

For optimum performance of this power connector, we recommend the use of Amphenol Socapex backshells :

Warning :

- for the 27 T receptacle, use a backshell size 25 (due to the reinforced connector shell).
-Example : HE 308-35-**25**-30-36 7 M for our
- for our 06 and 26 plugs, use a backshell size 23.
-Example : HE 308-35-**23**-30-32 7 M

Tool references (Dubuis crimping tool)

• For size 00 Contact

- Crimping pliers 922521
- Pliers adapter 922522
- Dies for 75 mm² 922517-90
- Dies for 100 mm² 922518-90

-Contact positioner for the dies 922519

The contact positioner is installed on the dies to allow a perfect positioning of the contact before crimping operation.

This positioner is the same for pin & socket and for 100 or 75mm² types.

-Insertion guide for 75 mm² 922507

-Insertion guide for 100 mm² 922525

The insertion guide ease insertion of the contact into the barrel before crimping.

- FACOM Clip pliers 922520

Connector assembling

- Contact seal lubricating (to ease insertion in the insert)
- Set up sealing O-ring on the contact
- Insert the contact and the seal in the front insert
- Set up rear insert
- Set up clips with the FACOM pliers
- Heat shrink sleeve necked with the heater generator



Installation instruction

• Wire preparation

- Before crimping, it is a must to place over the wire :
- The DR25 ¾ sleeve (insulation heat shrink sleeve)
- The clip for the contact retention
- The rear insert

Crimping process

Use the insertion help guide to allow easy installing the wire in the barrel.

See drawing enclosed.

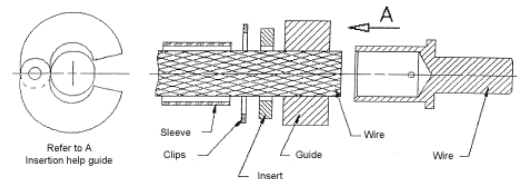

- Insert the wire until it appears in the inspection hole
 - Introduce the contact between the dies
 - Handle pliers until the hearing and sensitive click
 - Piston returns by rotating the free handle and closure.
- See pliers picture enclosed.

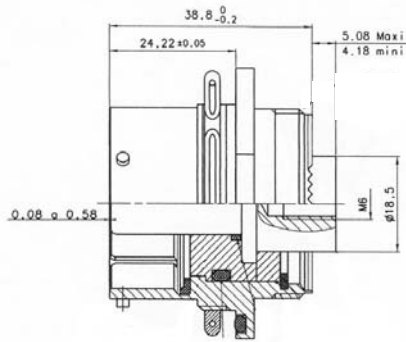

27T - Jam Nut Receptacle
(shown with crimp pin contact)

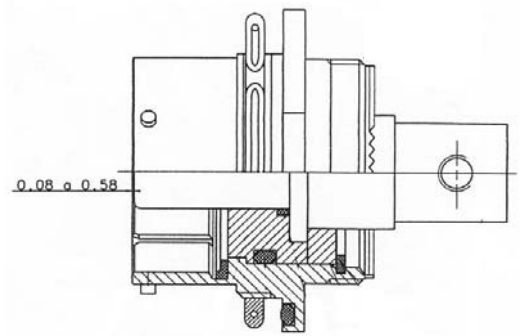

27T - Jam Nut Receptacle
(shown with terminal spade tag pin contact)

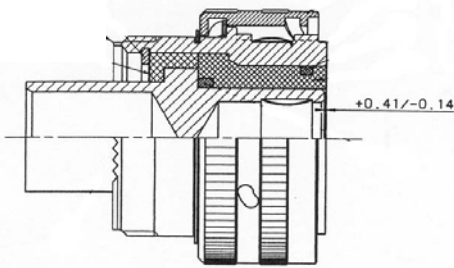

06T - Free Plug
(shown with crimp pin contact)

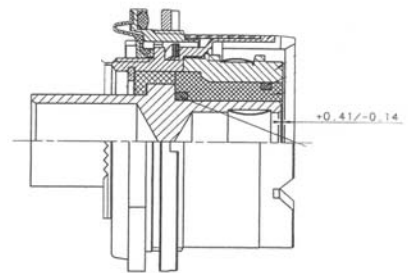

26T - Floating Plug (Rack & Panel)
(shown with crimp pin contact)

Panel drilling and recommended nut torque values

	Shell size	K min Mm (in)	W Mm (in)	Ø X (+/- 0.1) Mm (in)	Nut torque values N.m
Receptacle	23	50.60 (1.992)	19.12 (0.753)	41.50 (1.634)	12.4/13.6
Floating Plug	23	54.20 (2.134)	20.24 (0.797)	44.68 (1.759)	13.6/14.7

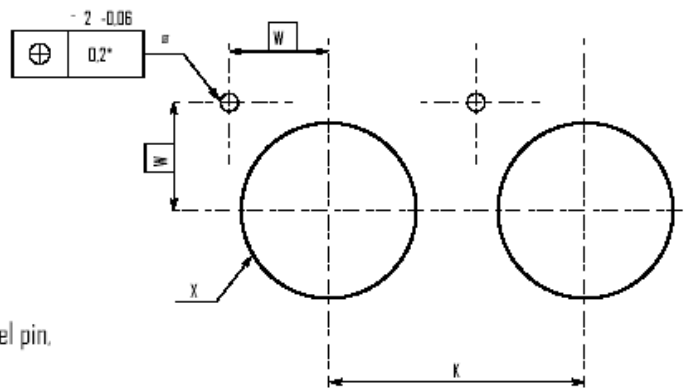

* Hole to be fitted with a stainless steel pin,
which must be inserted by force.
A stainless steel pin is supplied with connectors.

Please consult us for dimensional characteristics for rack and panel application (distance between panels, guiding fingers...)

HE 308 23-P1 (1 x 250 A) part-numbering :

Series	HE 308	06	T	23	O1	S	N	7	M	L
Shell type										
06 - Free plug										
26 - Floating Plug (for rack and pannel application)										
27 - Jam nut receptacle										
Class										
T - Environmental										
Shell size										
23										
Contacts arrangement										
01 - one 250 A contact										
Contact type										
P - Pin contact for receptacle only										
S - Socket contact for plug only										
Polarization										
N - normal only										
Shell Finish										
7 - Olive drab cadmium										
6 - Nickel plated										
Conforms to DTAT specification										
L - Connector supplied without contact.										
Contacts must be ordered separately. Please see Part Number here below mentioned.										

Proprietary part-numbering :

- HE308 06 T 23 O1SN7ML : LJT06RT23P1S014LC
- HE30826 T 23 O1SN7ML : RNJ26T23P1SN014LC
- HE30827 T 23 O1PN7ML : RNJ27T23P1PN014LC
- HE308 06 T 23 O1SN6ML : LJT06RT23P1S023LC
- HE30826 T 23 O1SN6ML : RNJ26T23P1SN023LC
- HE30827 T 23 O1PN6ML : RNJ27T23P1PN023LC

Remark : Polarization « A » is also available (in proprietary part-number only, and in LJT06 and RNJ27 shell configurations only)

Example : LJT06RT23P1S A 014LC which mates with RNJ27T23P1P A 014LC

Contacts part numbers :

Part numbers	Designation	Acceptable wire section	HE308 Mil Standard
900161	250 A crimp socket contact	100 mm ²	HE 308 C 2D 10 SM
900162	250 A Pin contact for terminal spade tag	75 mm ² 100 mm ²	HE 308 V 2D 00 PM
900169	250 A crimp socket contact	75 mm ²	HE 308 C 2D 8 SM
900170	250 A crimp pin contact	75 mm ²	HE 308 C 2D 8 PM
900171	250 A crimp pin contact	100 mm ²	HE 308 C 2D 10 PM