

IP67/68 rugged Ethernet Managed Switch RES-SCE-8MG - Hardware User Manual –

Contents

Section 1	General Information	Page 3
Section 2	Hardware	Page 4
Section 3	Installation	Page 5
Section 4	Wiring	Page 7
Section 5	Management	Page 9
Section 6	Features Overview	Page 10
Section 7	Service Information	Page 12

This manual applies to the following products:

- **RES-SCE-8MG (NOLED) (other options)**
Rugged IP67/68 Managed Ethernet Switch, with SCE2 reinforced connectors

Revision	Date	Modifications
1	November 19, 2013	Initial document
2	December 11, 2013	Updated weight, power consumption and default IP address
2.1	July 09, 2014	Updated rear view of the plug for Ethernet port
2.2	April 25, 2016	Updated pinout wiring description for Ethernet port

Amphenol Statement of Limited Warranty:

Products shall benefit from a legal guarantee of one year following the date of delivery in accordance with the terms and conditions indicated hereunder.

In all instances, Seller's guarantee shall be limited to free replacement, in identical quantities, of the Product acknowledged as defective by Seller with the exclusion of any compensation or damages and interests other than agreed in a specific contract.

The guarantee is subject that Client notifies Seller of defect immediately following discovery thereof by any written means during the legal guarantee period. Defective Products shall be returned to Seller in accordance with the same procedure as that applicable to Products which do not comply with orders as indicated under article 9 hereinabove.

The following shall be excluded from the guarantees provided by Seller:

- Product defects resulting from inadequate maintenance, or supervision and, more widely, any use which does not comply with written instructions of Seller and indicated in technical notices and/or product specifications, or default in respecting applicable standards or professional customs and uses;
- Product defects resulting from an external cause or any modification or intervention by Client or third party without the prior written consent of Seller;
- The guarantee shall not cover normal wear and tear of Products;
- Product defects resulting generally in whole or in part from damage or accidents attributable to Client or a third party;
- More specifically whether the cover of the switch enclosure have been opened.
- Whether the components have been damaged in transit or have not been stored by the Customer in conditions in accordance with the specification.
- The guarantee shall not cover any defects resulting from instructions given by Client to Seller ;
- Whether the components have been subjected to abuse (mechanical, electrical or thermal) on installation or on use and, in the case of slices/dice, have been subjected to handling or such operations as the welding of connecting wires mounting by soldering or sticking.
- Whether the unfitness or defectiveness of the components has resulted from exceeding the maximum values for usage (temperature limit, maximum voltage, etc.) as defined by the Vendor, or from incorrect choice of application.
- Damages resulting from force majeure, such as this is defined under article 11 of Amphenol Socapex Sales Conditions hereunder, or resulting from any unpredictable event or natural disaster.
- Furthermore, the guarantee shall not cover consequential liability, direct or indirect which may result from the failure of a component supplied by the Vendor.

Client shall retain sole and exclusive liability for the use of Products provided by Seller and the suitability thereof for use.

Client should ensure that its premises and storage conditions are adequate for the due and proper storage of Products and ensure all safety guarantees as stipulated by regulations in force. No guarantee shall be provided by Seller in this regard.

CE Declaration of conformity:

This equipment complies with the requirements relating to electromagnetic compatibility and security.

EN55022 (Emissions);

EN55024 (EN50082-1 ou -2) et/ou EN61326-1 (Immunity);

EN61010-1 ou EN60950 (Electrical safety);

This meets the essential protection requirements of the European Council Directive 89/336/EEC on the approximation of the laws of the Member States relating to electromagnetic compatibility.

Note: All information in this document is subject to change without notice.

Section 1

General Information

Overview

This manual will help you install and maintain the Amphenol Rugged Ethernet Managed switches. These products are extremely easy to install and operate.

Military applications can now take full advantage of 1000Mbps Gigabit Ethernet performance.

The installation guide describes how to install and use the hardened compact Ethernet RES-SCE-8MG Military Rugged Switch. Capable of operating at extreme temperature of -35°C to +75°C and meet the toughest industrial and military environments such as MIL-STD-810F, MIL-STD-1275B, MIL-STD-461E up to the highest levels. The mentioned ability turns the RES-SCE-8MG to the optimal solutions switch of choice for harsh environments constrained by space.

Developed for military and harsh mobile applications, the RES-SCE-8MG features mechanical packaging enhancements designed for MIL-STD-810F airborne and ground environmental compliance and high reliability. The unit has been especially hardened to improve ingress, impact, and shock/vibration protection, as well as eliminate all moving parts through passive cooling, and interface through sealed SCE2 reinforced circular connectors.

Leveraging best-in-class switching technology, the RES-SCE-8MG serves as a robust solution for providing local area network (LAN) connectivity to IP-enabled computing and net-centric devices. Compact in size, the RES-SCE-8MG is particularly useful for expanding port density to tactical IP routers in space-constrained airborne and ground vehicle environments.

RES-SCE-8MG is specifically designed for Data Acquisition & Transmission, Battlefield Communication C4ISR, Rugged Networks, Mobile Communications, Combat vehicles and Avionic & Shipboard Systems.

Performance Specifications

These general specifications apply to these switches. Refer to Section 6 for complete technical specifications.

Ports	10/100/1000BaseTx
Voltage	24Vdc Nominal (16-36V) Power Consumption: 7.2W Max, 5W Typ.
MIL standards	MILSTD-1275, MILSTD-461E, MILSTD-810F GM
Electromagnetic	MIL-STD-461E Electromagnetic compatibility CE-102, CS-114, CS-115, CS-116, RE-102, RS-103
Operating Temp.	-35°C to +75°C (-31°F to +167°F) -35°C Cold Start-Up
Waterproof	IP67/68

Section 2

Hardware

Overview

The switches can be mounted directly to a flat surface or to a wall. Refer to the mechanical drawing below. Its high protected enclosure makes it able to withstand immersion (IP67/68 rating).

The Ethernet connections come out from rugged SCE2 connectors.

Front Panel Display

The following describes the front panel, and LED indicators of the RES-SCE-8MG.

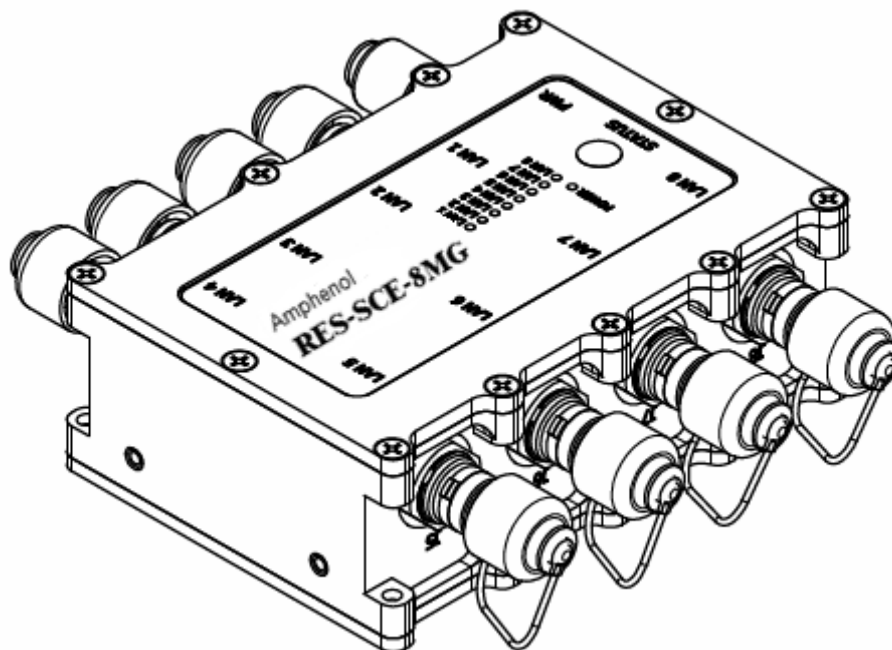

LED Indicators

Note: Due to Tactical requirements, LED's will ONLY operate while pressing and holding the marked "Push-Button"!

The Single LED indicator on the front panel positioned above the "Push-Button" shows the operative status of the switch.

Once the LED is turned on, the switch is powered and ready-for-use.

This LED will be on solid yellow/green when proper power has been applied to the unit.

Above the single "power" LED you will find 8 additional LED's.

- Each port has a single LED's indicator that indicates Link / Activity (Off – there is no link, Steady Green – There is a device connected, Flashing Green – data is being transmitted)

Section 3

Installation

Selecting a Site

As with any electronic device, you should place the switch where it will not be subject to extreme temperatures, humidity, or electromagnetic interference that exceeds the RES-SCE-8MG's profile. Specifically, the site you select should meet the following requirements:

- The ambient temperature should be between -35°C to 75°C.
- The relative humidity is recommended to be less than 95% percent, non-condensing.
- Surrounding electrical devices should not exceed the electromagnetic field (RFC) standards for MIL-STD-461E.

CAPS for unused connectors

The switches are pre-equipped with caps on all ports, including power and Ethernet.

→ **Make sure all connectors are protected with cap or sealed plug to ensure sealing and prevent from deterioration of the contacts.**

Mounting

The RES-SCE-8MG Ethernet Switch can be fastened to any flat surface by mounting the box directly. Refer to the mechanical drawings below. Make sure to allow enough room to route your Ethernet and power cables.

The RES-SCE-8MG weighs 390 grams and is mounted via its four 4-40 threads. The external dimensions of the RES-SCE-8MG are given here after.

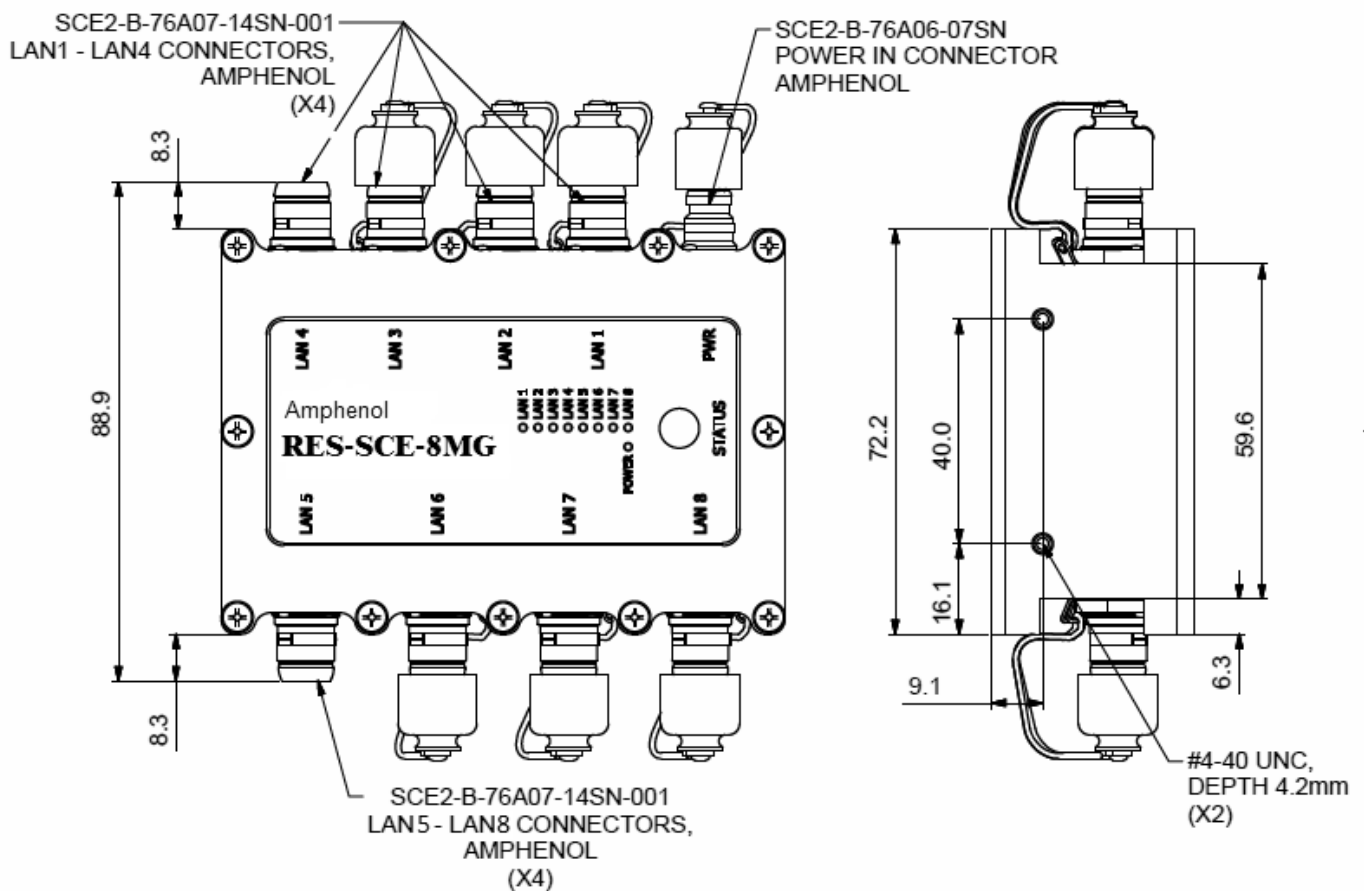

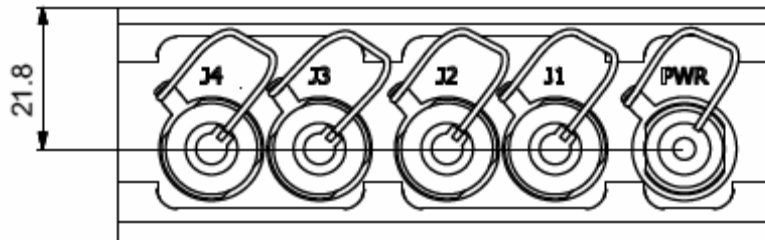
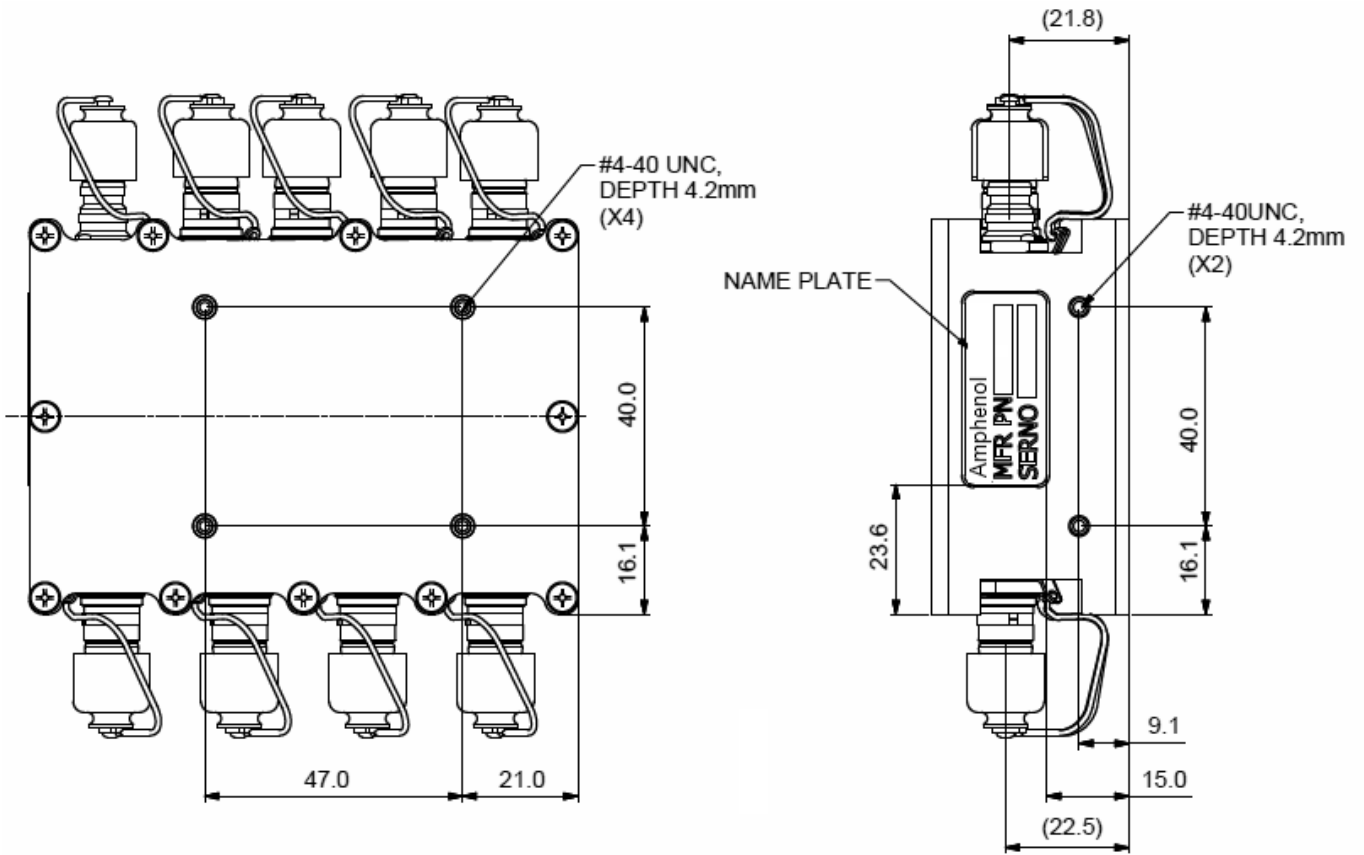

Section 4

Wiring

Overview

These switches provide connections to Ethernet devices in harsh environment. Typically a port is used to connect to another Ethernet switch that is connected to the main Ethernet backbone. The other Ethernet ports are then connected to Ethernet devices such as communication systems, Ethernet I/O, or industrial computers. Electrical isolation is provided on the Ethernet ports for increased reliability.

Power wiring

Power plug

This switch is powered by using port number PWR.

We suggest using SCE2-B-L1K06-07PN.

Note : pay attention to use the cable's shield for the ground continuity during the wiring process.

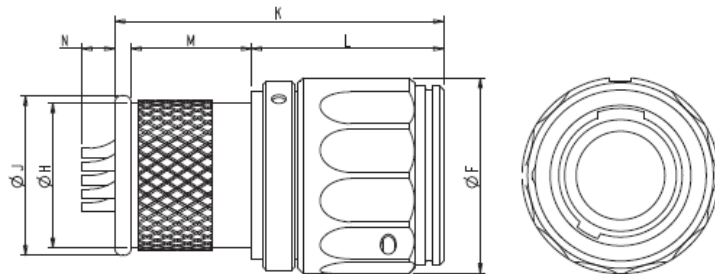

Shell Size	ØF	ØH	ØJ	K	L	M	N
Size 06	.540 (13.75)	.399 (10.14)	.440 (11.18)	.902 (22.91)	.527 (13.39)	.330 (8.38)	.090 (2.29)

Power plug wiring

Pin	Signal	Description
A	N/C	N/C
B	N/C	N/C
C	N/C	N/C
D	VCC	24 VDC
E	GND	Digital Ground
F	N/C	N/C
G	N/C	N/C

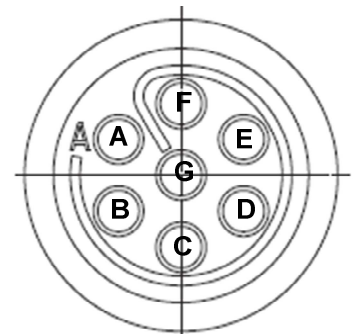

rear view of the plug

Accessories such as heatshrinks boots, braid retention strap and metal dust caps can be offered. Consult the TERRAPIN catalog for further details.

Here are the heatshrinks suggested for using with SCE2-B-L1K06-07PN:

Right angled or Straight boot	Amphenol P/N
Straight	123GB-0798-06-S
Right angled	123GB-0798-06-R

Ethernet wiring

These switches provide connections to Ethernet devices on the battlefield. Typically a port is used to connect to another Ethernet switch or hub that is connected to the main Ethernet backbone. The other Ethernet ports are then connected to Ethernet devices such as communication systems, Ethernet I/O, or industrial computers. Electrical isolation is provided on the Ethernet ports for increased reliability.

Please follow normal Ethernet wiring practices when installing these switches.

Use data-quality (not voice-quality) twisted pair cable rated category 5E (or better) with SCE2 connector.

Ethernet plug part number

The 8 ports Ethernet connectors are LAN 1 to LAN 8.

The switches should be connected using mating inline receptacles from SCE Terrapin series. We suggest using the L1K Latch inline receptacle or 01K Snatch inline receptacle.

P/N for the latch inline receptacle: SCE2-B-L1K07-14PN.

Note: A grounding ring is provided with the 985 option.

P/N for the latch inline receptacle with grounding ring: SCE2-B-L1K07-14PN-985.

Note : pay attention to use the cable's shield for the ground continuity during the wiring process.

Ethernet plug wiring



SCE2-B-L1K07-14PN-985

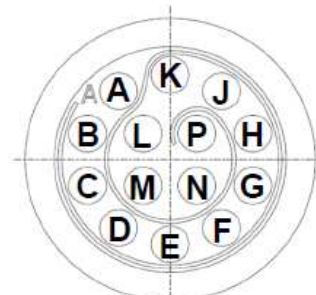

rear view of the plug

This plug has size 7. It is coming with 14 contacts 23 AWG with solder termination. Only contacts A to H should be connected following to below wiring, as per TIA/EIA-568B:

SCE2	RJ-45	Signal type	Colour
A	1	DA+	White / Orange
B	2	DA-	Orange
C	3	DB+	White / Green
D	4	DC+	Blue
E	5	DC-	White / Blue
F	6	DB-	Green
G	7	DD+	White / Brown
H	8	DD-	Brown

Accessories such as heatshrinks boots, braid retention strap and metal dust caps can be offered. Consult the TERRAPIN catalog for further details.

Here are the heatshrinks suggested for using with SCE2-B-L1K07-14PN:

Right angled or Straight boot	Amphenol P/N	Raychem Tyco P/N	Hellerman P/N
Straight	123GB-0798-07-S	202K132-25/225	154-44-GW24
Right angled	123GB-0798-07-R	202D132-25/225	1107-4-GW24

Section 5

Management

Management

The switch is managed. The preferred method for accessing to the switch is the web interface.

It can be also accessed using RS-232 console port (shared on port LAN 1).

Web management

For in-band Ethernet management configuration use either one of the 8 ports.

Configure your computer with compatible IP address and access to the switch using a web browser.

Switch default IP address: 192.168.1.111

Mask: 255.255.255.0

Gateway: [empty].

Enter 'admin' for the password.

You have now access to the configuration settings. You can enter your desired IP address and subnet, or enable DHCP.

Serial management

There is one serial port associated with the Management Processor, MNG.

RS-232 is accessible on port LAN 1.

Accessory connector P/N: SCE2 L1K 07 14 PN

This port is RS-232 compatible and can operate only at:

- 115,200 baud rate
- 1 Stop Bits
- No Parity
- No Flow Control

The MNG port supports out-of-band configuration management of the switch.

SCE Pinout	Direction	Type	DB9 Pinout
M	Output	RS-232	TX (PIN 2)
N	Input	RS-232	RX (PIN 3)
P	Reference	Ground	GND (PIN 5)

RS-232 pinout on LAN 1 port

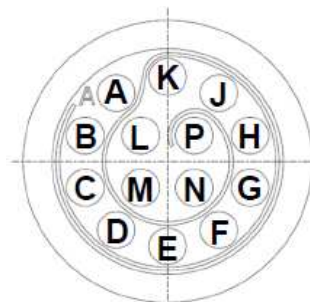

rear view of the plug

→ Consult the dedicated Command Line Interface User Manual for getting all details regarding the commands description.

Section 6

Switching Features

Features Overview

Here's a brief explanation of some of the features found in these switches documented by this manual.

ETHERNET PORTS

- 8 x switched 10/100/1000 (Gigabit Ethernet) ports

STANDARDS COMPLIANCE

- IEEE 802.1x MAC based Authentication
- IEEE 802.1Q Vlan Tagging
- IEEE 802.1P QoS
- IEEE 802.1S Multiple STP
- IEEE 802.1W Rapid STP
- IEEE 802.1AD Link Aggregation

NETWORKING

- Spanning Tree (802.1d), RSTP (802.1w) and multiple Spanning Tree (802.1S) for fast recovery rings
- Security via Radius Authentication 802.1x, Port Security, Port Mirroring
- Multicasting (IGMP Snooping), GARP, GMRP, and GVRP Broadcasting and flooding Control up to 8K Groups.
- 802.1q Tagged based VLAN up to 4K VLAN groups.
- QoS Multi-Layer Classifier, 802.1p, ToS/DSCP traffic classification. WFQ, Strict Queuing.
- Bridge support for Q-in-Q.
- Link Aggregation 802.3AD.
- WEB, CLI, Telnet Management.

STANDARDS

- MILSTD-1275
- MILSTD-461E
- MIL-STD-704
- MILSTD-810F GM
- IP67 / 68

PERFORMANCE

- 26.8 Mpps wire speed forwarding rate
- 20 Gbps maximum forwarding bandwidth
- 8K MAC Address

CHASSIS

- Low profile rugged machined aluminum
- Conductively cooled w/custom internal heat-sinks
- Ingress protection against sand, dust and moisture
- Anodize Coating, MIL-A-8625, Type II, Class 2

POWER

- Exceed MIL-STD-1275 Surge and Spike protection
- Voltage Input: 24Vdc Nominal (16-36V)
- Power Consumption: 5W Typical; 7.2W Maximum
- Ground: Grounding screw provided for connection to system chassis ground

ELECTROMAGNETIC

- MIL-STD-461E Electromagnetic compatibility
- CE-102, CS-114, CS-115, CS-116, RE-102, RS-103

SHOCK/VIBRATION/HUMIDITY

- MIL-STD-810F
 - Random vibration (514.5I), Bench Handling (516.6VI), High Temp.(501.5I,II), Low Temp.(502.5I), Humidity, (507.5II), Air Pressure (500.5I,II), Blowing Rain (506.5I), Immersion (512.5I), Salt Atmosphere (509.5I), Blowing Dust (510.5I), Loose Cargo Vibration (514.6II), Wind Analysis.
- IP67/68

PHYSICAL

- Weight: 390g
- No Moving Parts. Passive Cooling
- Installation: Set of Four 4x4.5 mounting holes on bottom for mounting to any flat surface.

OPERATING AND STORAGE TEMPERATURE

- Operating temp: -35°C to +75°C (-31°F to +167°F) – -35°C Cold Start-Up
- Storage temp: -45°C to +85°C (-49°F to +185°F)

Section 7

Service Information

Service Information

We sincerely hope that you never experience a problem with any **Amphenol** product. If you do need service, call **Amphenol** at +33(0) 450 89 28 00 and ask for Applications Engineering. A trained specialist will help you to quickly determine the source of the problem. Many problems are easily resolved with a single phone call. If it is necessary to return a unit to us, an RMA (Return Material Authorization) number will be given to you.

Amphenol tracks the flow of returned material with our RMA system to ensure speedy service. You must include this RMA number on the outside of the box so that your return can be processed immediately.

The applications engineer you are speaking with will fill out an RMA request for you. If the unit has a serial number, we will not need detailed financial information. Otherwise, be sure to have your original purchase order number and date purchased available.

We suggest that you give us a repair purchase order number in case the repair is not covered under our warranty. You will not be billed if the repair is covered under warranty.

Please supply us with as many details about the problem as you can. The information you supply will be written on the RMA form and supplied to the repair department before your unit arrives. This helps us to provide you with the best service, in the fastest manner. Normally, repairs are completed in two days. Sometimes difficult problems take a little longer to solve.

We apologize for any inconvenience that the need for repair may cause you. We hope that our rapid service meets your needs. If you have any suggestions to help us improve our service, please give us a call. We appreciate your ideas and will respond to them.

For Your Convenience:

Please fill in the following and keep this manual with your **Amphenol** system for future reference:

P.O. #: _____ Date Purchased: _____

Purchased From: _____

Product Support

To obtain support for Amphenol products:

Visit our website. <http://www.rjswitch.com>

Phone: +33(0) 450 89 28 00

Fax: +33(0) 450 96 29 75

E-mail: <mailto:contact@rjswitch.com>

Mailing Address: Amphenol, Promenade de l'Arve, B.P.29, 74311 Thyez Cedex, France

For more information

You will find all useful information on the RJ-Switch series on the dedicated website:

<http://www.rjswitch.com>