

PS SERIES PSMATPHDCU276U2500-X

Three Phase AC/DC POWER SUPPLY



- AC/DC POWER SUPPLY
- INPUT 230VAC 60Hz

- OUT RANGE 100 to 320 VDC
- UP TO 2500W

Special Features

- Compact size
- High efficiency
- Wide input range
- Input / Output isolation
- Fixed switching frequency (approx. 400 kHz)
- Remote Inhibit (On/Off)
- EMI filters included
- Limited Inrush Current
- Indefinite short circuit protection with auto-recovery
- Over temperature shutdown with auto-recovery

Environmental Conditions

Meets or exceeds MIL-STD-810G

Temperature:

Operating -55 °C to +85 °C (at baseplate)

Storage -55 °C to +125 °C

Reliability

150000 hours, calculated IAW MIL-HDBK-217F
Notice 2 at +85 °C baseplate, Ground Fix environment.

Electrical Specifications

AC INPUT

Input Voltage Range:

3-phase 230 V_{RMS,L-N} ± 20% / 50 Hz

Over-voltage lockout: Above 300 V_{RMS,L-N}

Efficiency: 86%, typical (270V variant, nominal input line, maximum load)

Power Factor: Minimum 0.8 from 50% load

EMC: Designed to meet* MIL-STD-461F: CS101, CS114, CS115, CS116, RE102, RS103 with external filter and shielded cable.

Isolation:

1000 V_{DC} between Input and Output

1000 V_{DC} between Input and Case

DC OUTPUT (floating from input)

Voltage Range: 100 to 320 V_{DC}

Current Range: 0 to 20 A

Power Range: 0 to 2500 W

Line/Load Regulation:

Less than ±1% (0 to 100% load, -55 °C to +85 °C and over input voltage range)

Ripple and Noise: 500 mV_{p-p}, typical (Up to 1%)

Overload / Short-Circuit Protection:

Current limit at moderated overload, hiccup at high overload to short circuit.

Over-Voltage Protection:

Passive transorb on output.

Over Temperature Protection:

Shutdown if baseplate temperature exceeds +105 °C ± 5 °C;
Automatic recovery on cool-down to below +95 °C ± 5 °C

Isolation:

500 V_{DC} between Output and Case.

† When using shielded cables and static resistive load.

Markets & Applications



Military, ruggedized, ground radar



Telecom, industrial

PS Series: PSMATPHDCU276P2500-X

Pin Assignment

CONNECTOR J1 (INPUT)

Connector type: D38999/20WD5PN or eq.

Mating connector: D38999/26WD5SN or eq.

Function	Pin No.	
PHASE A	A	●
PHASE B	B	●
PHASE C	C	●
SPARE	D	
CHASSIS	E	●

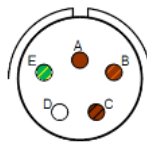

CONNECTOR J2 (OUTPUT)

Connector type: D38999/20WD19SN or eq.

Mating connector: D38999/26WD19PN or eq.

Function	Pin No.	Polarity	
V _{OUT}	A, B, C, P, R	+	●
V _{OUT} RTN	J, K, L, T, U	-	●
INHIBIT	G	+	●
INHIBIT RTN	F	-	⊕
PWR GOOD	D	+	●
PWR GOOD RTN	E	-	⊕
SPARE	H, M, N, S, V		

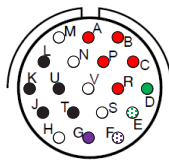

PS Series: PSMATPHDCU276P2500-X

Functions and Signals

INHIBIT signal (connector J2, pin G)

The **INHIBIT** signal is used to turn the power supply ON and OFF.

To turn the power supply ON, leave pin G open.

To turn the power supply OFF, short pin G to pin F.

If not used, leave pin G unconnected.

This signal is referenced to **INHIBIT RTN (connector J2, pin F)**

PWR GOOD signal (connector J2, pin D)

The **PWR GOOD** signal indicates the status of the output voltage.

When output voltage rises above $95\% \pm 5\%$ of its nominal value, pin 10 will be pulled down to pin 13 through a $49.9\ \Omega \pm 1\%$ resistor and a phototransistor.

When output voltage falls below $90\% \pm 5\%$ of its nominal value, pin 10 will be in high impedance mode.

If not used, leave the signal unconnected.

This signal is referenced to **PWR GOOD RTN (connector J2, pin E)**

Both pins 10 and 13 are isolated from all other parts of the circuitry.

Typical Connection Diagram

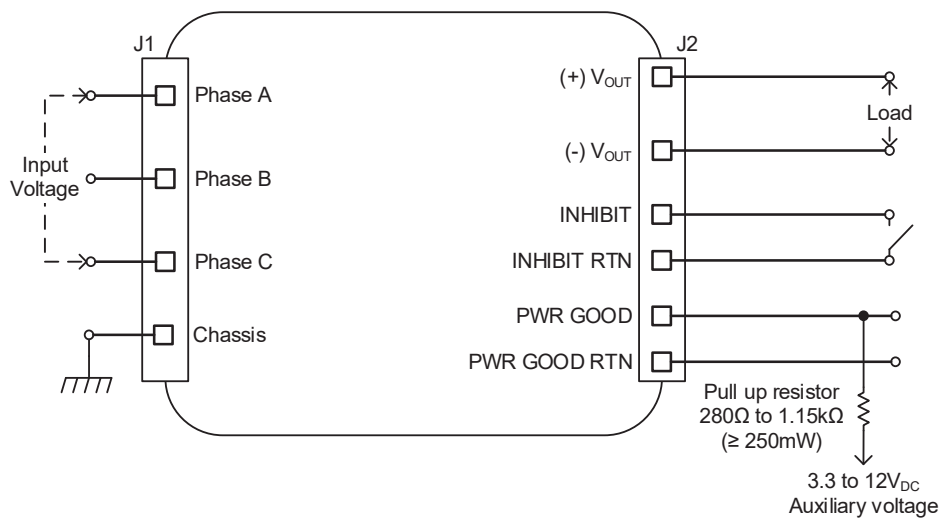

Note: PWR GOOD pull-up resistor and auxiliary voltage shown in this diagram are typical values. The system designer must select the actual values such that no damage can occur to the internal components of the power supply – **consult factory for more information.**

PS Series: PSMATPHDCU276P2500-X

Outline Drawing

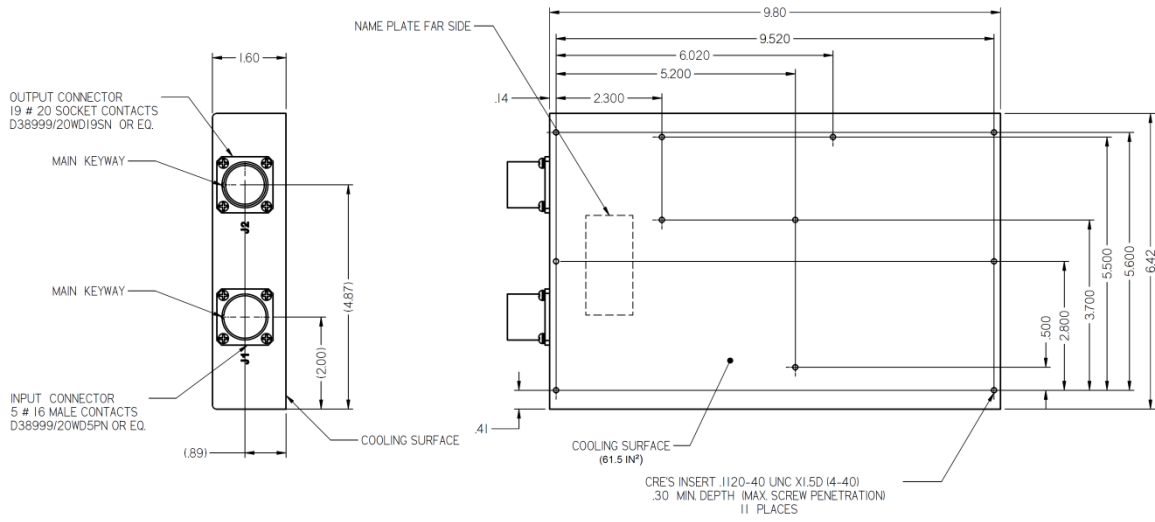

Heat Dissipation Surface Area

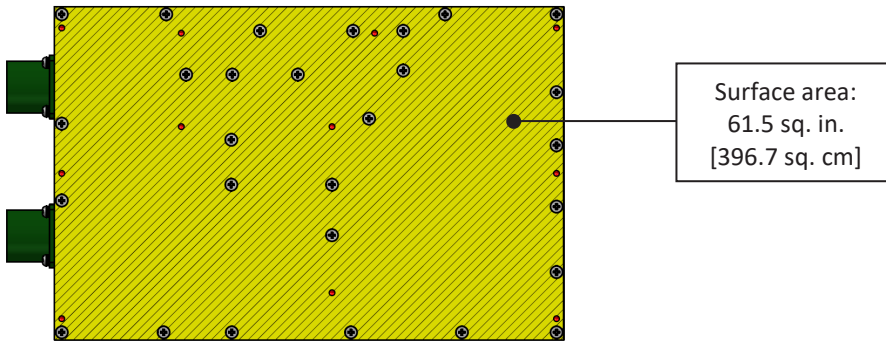

Notes

1. Dimensions are in Inches
2. Tolerance is:
.XX ± .025 in
.XXX ± .010 in
3. Weight: Approx. TBD lbs. [TBD kg]

PS Series: PSMATPHDCU276P2500-X

Standard Configurations

Part number	Input		Output	
	Voltage range	Frequency	Voltage	Current
PSMATPHDCU276P2500-3	3-phase, 207 to 253 V _{AC}	50 Hz	270 V _{DC}	9.5 A

Additional configuration available. **Consult factory for details**

Note: Specifications are subject to change without prior notice by the manufacturer

