

## PS SERIES PSVA3UTPU125P800-X VPX AC/DC POWER SUPPLY

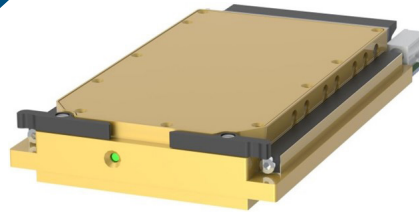

- 1.0 Pitch, 3U VPX form factor
- High power output + Aux output

- Up to 800W

### Special Features

- 1.0 Pitch, 3U IAW VITA 62
  - High efficiency
- Input / Output isolation
  - EMI filters included
- Fixed switching frequency
  - Remote Inhibit
  - Remote Enable
- Non-latching protections:
  - Short-circuit/overload
  - Output over-voltage
  - Over temperature

### Electrical Specifications

#### AC Input

103 to 125 V<sub>phase-Neutral</sub>  
400 Hz  
Three-Phase

#### DC Outputs (standard version)

VS1	28 V <sub>DC</sub>	30 A
3.3V_Aux	3.3 V <sub>DC</sub>	0.4 A

#### Isolation

Input to Output: 1000 V<sub>DC</sub>  
Input to Case: 1000 V<sub>DC</sub>  
Output to Case: 200 V<sub>DC</sub>

No damage (may shut down) if exposed to normal/abnormal transients IAW MIL-STD-704A/F & DO-160G

VS1 capable of 1150 W @ 71 °C

#### Output voltage regulation

±1% or better (no load to full load, low line to high line, -40 °C to +71 °C at card edges).

#### Efficiency

Typical 90% (Nominal line, nominal load, room temperature)

#### EMC

Internal EMI filter included. Compliance with MIL-STD-461F CE102, CS101, CS114, CS115 & CS116 possible with external filter.

#### Ripple and Noise

Less than 100 mV<sub>p-p</sub>, typical (max. 1%) without external capacitance. When connected to system capacitance ripple drops significantly.

#### Output Under-and-overshoot

Output impedance at load step of 50%-100% is 30 to 120 mΩ (depending on output voltage). Output resumes steady-state within 300-500 μs.

## Markets & Applications



Military : airborne, ground-fix, shipboard



Ruggedized, Telecom, Industrial Power Supply

# PS SERIES: PSVA3UTPU125P800-X

**Protections** (Thresholds and protections can be modified / removed – please consult factory).

## Input

- **Inrush Current Limiter**
- **Under Voltage Lock-Out**  
Unit shuts down when input voltage is below  $90 V_{ac}$ .

## Output

- **Active Over-Voltage**  
Threshold set at  $110\% \pm 5\%$  of nominal voltage.
- **Passive Over-Voltage**  
Threshold selected at  $120\% \pm 10\%$  of nominal voltage.
- **Overload / Short-Circuit**  
Protected against indefinite short circuit by a hiccup mechanism (periodical off/on until short is removed).  
Threshold set at  $120\% \pm 10\%$  of maximum current.

## General

- **Over-Temperature Protection:**  
Shutdown if temperature exceeds  $+105 \pm 5 \text{ }^\circ\text{C}$ .  
Automatic recovery upon cooldown to below  $+90 \pm 5 \text{ }^\circ\text{C}$ .

## **Environmental Conditions**

Designed to meet MIL-STD-810G

### Temperature

Operating:  $-40 \text{ }^\circ\text{C}$  to  $+85 \text{ }^\circ\text{C}$   
(at plug-in card edge, IAW VITA 62 CC3)

Storage:  $-55 \text{ }^\circ\text{C}$  to  $+105 \text{ }^\circ\text{C}$

### Humidity

Method 507.5  
Up to RH 95%

### Altitude

Method 500.5, Procedure II  
(Operational)

### Salt Fog

Method 509.5

### Vibration

Method 514.6  
Procedure I  
Category 24 - General  
minimum integrity exposure

### Shock

Method 516.6  
Procedure I  
Saw-tooth, 20g peak, 11ms.

## **Reliability**

At least 100,000 hours, calculated IAW MIL-HDBK-217F Notice 2 at  $+85 \text{ }^\circ\text{C}$  at wedge lock edge, Ground Fix condition.

## **Environmental Stress Screening (ESS)**

100% of units are tested at minimum and maximum operational temperature, in addition to an ATP in room ambient. Random vibration and thermal cycles can be added if required. **Please contact factory for details and a quote.**

# PS SERIES: PSVA3UTPU125P800-X

## Pin Assignment

### Connector P0

Connector type: TYCO 1-6450839-4 or eq.

Mating connector type: TYCO 2-6450869-7 or eq.

Pin Number	Signal Name	Function
LP1	PHASE A	Input voltage phase A
LP3	PHASE B	Input voltage phase B
LP5	PHASE C	Input voltage phase C
LP7	NEUTRAL	N/C
LP9	HOLDUP_P	Positive output/input to/from holdup module
LP11	HOLDUP_N	Negative output/input to/from holdup module
LP13	CHASSIS	Chassis
A1	GA0*	N/C
A2	GA1*	N/C
A3	SYS_RESET*	N/C
B1	SMO	N/C
B2	SM1	N/C
B3	UDO	N/C
C1	UD1	N/C
C2	INHIBIT*	Output disable signal
C3	FAIL*	Failure indication signal
D1	SIGNAL_RTN	Return line for signals and 3.3V_AUX
D2	ENABLE*	Input enable signal
D3	3.3V_AUX	Auxiliary voltage, isolated from the main output
P1	OUTPUT	
P2	OUTPUT_RTN	

PART NUMBER	ROWS	POWER													SIGNAL			POWER	
		LP1	LP2	LP3	LP4	LP5	LP6	LP7	LP8	LP9	LP10	LP11	LP12	LP13	1	2	3	P1	P2
1-6450839-4	D														J	J	J		
	C	LM	-	LM	-	LM	-	LM	-	LM	-	LM	-	LM	K	K	K	TM	TM
	B														N	N	N		
	A														S	S	S		
13LP+12S+2P																			

### *Functions and Signals*

#### **ENABLE\*** (pin D2)

This signal is used to enable the input power of the converter.  
Connect this pin to **SIGNAL\_RTN** (pin D1) to enable input power.  
Leave open to disable input power.

#### **INHIBIT\*** (pin C2)

This signal is used to disable the main output of the converter.  
Connect this pin to **SIGNAL\_RTN** (pin D1) to disable the main output power.  
Leave open to enable the main output power.

#### **FAIL\*** (pin C3)

This signal indicates the status of the outputs.  
If the any of the output voltages drop below  $85\% \pm 5\%$  the signal will go 'high'.  
In case any of the output voltages rise above  $90\% \pm 5\%$ , the signal will be 'low'.  
Typical hysteresis for main output (example is 28 V) is 2%.  
Typical hysteresis for 3.3V\_AUX is 0.5%.  
Signal type: Open-drain (connect an external pull-up resistor to 3.3V\_AUX for voltage indication).  
This signal is referenced to **SIGNAL\_RTN** (pins D1)

#### **HOLDUP P/HOLDUP N** (pin LP9/LP11)

These pins are connected to the internal DC bus of the converter (the rectified input voltage).  
Connect these pins to the appropriate pins of the Hold up Module to add a holdup feature to the converter to provide a transparent ride-through during power interrupt events, IAW MIL-STD-704A-F.

Typical Connection Diagram

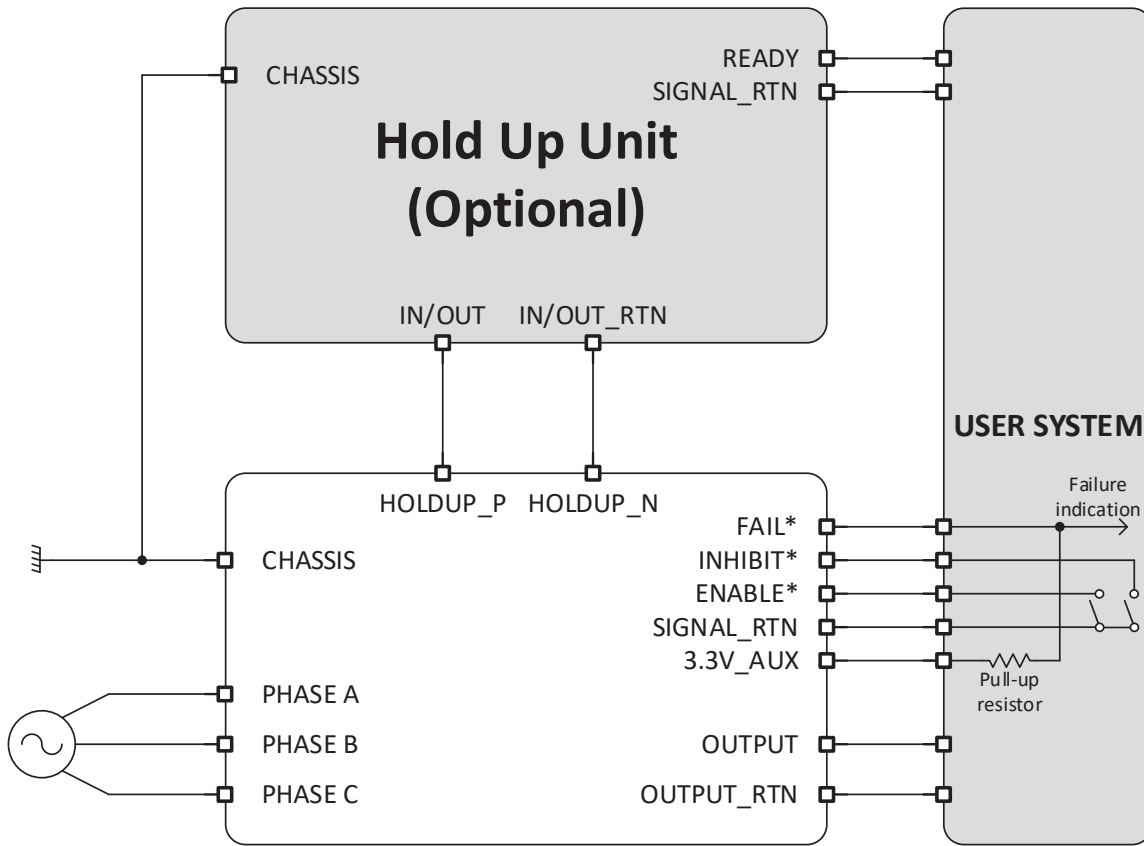

Outline Drawing

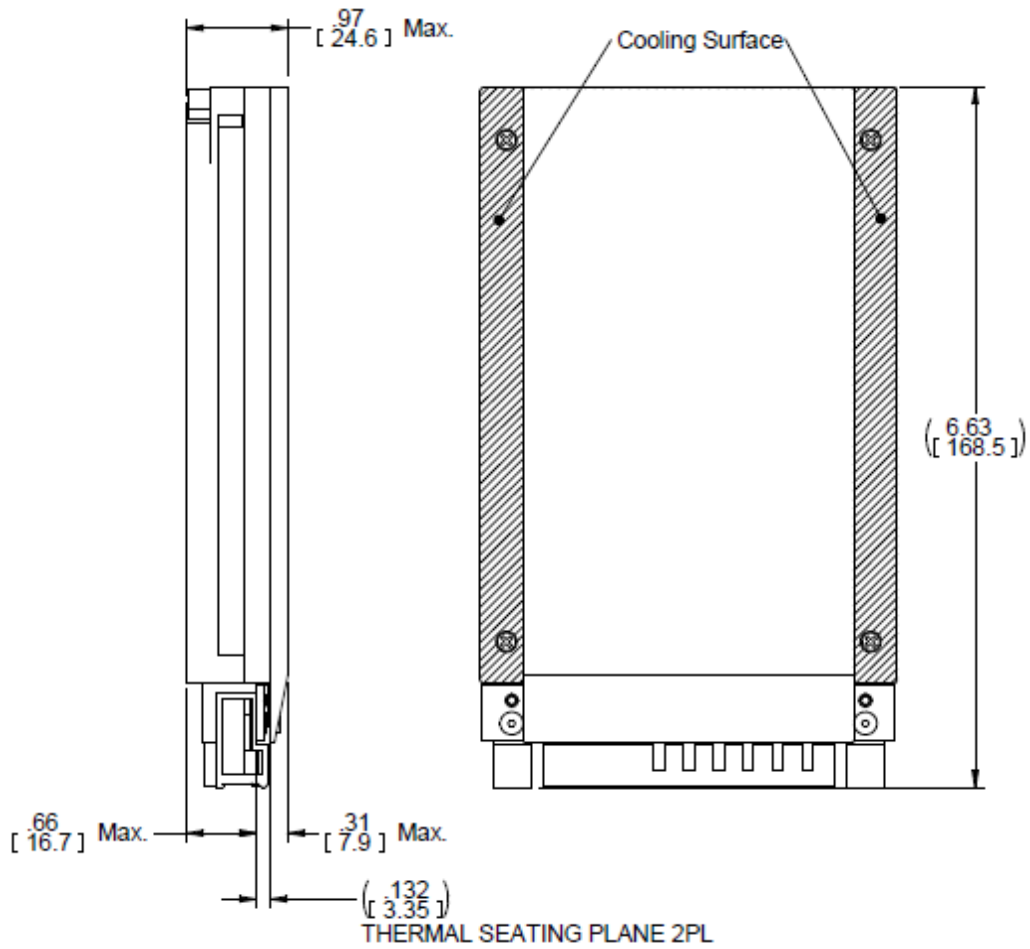

# PS SERIES: PSVA3UTPU125P800-X

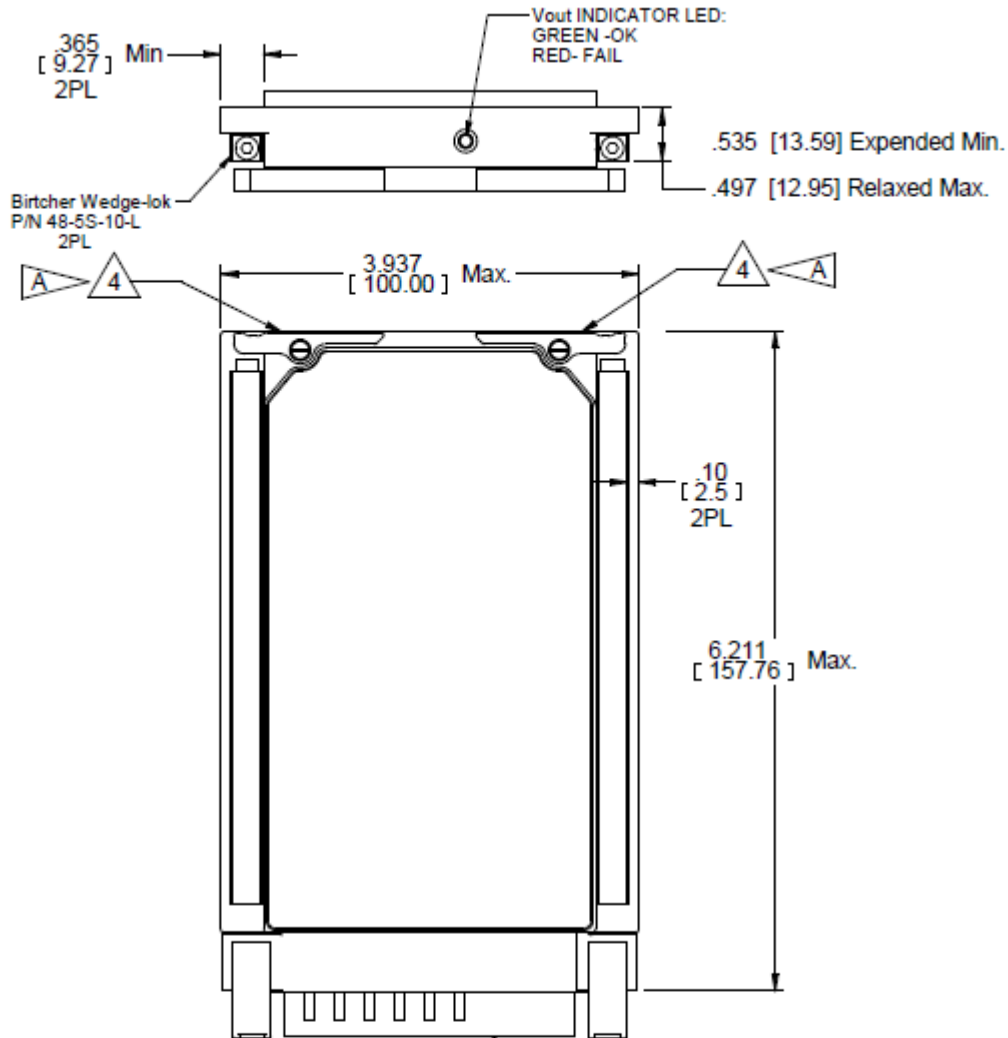

**B** I/O CONNECTOR: TYCO P/N 2332791-1 OR EQ.

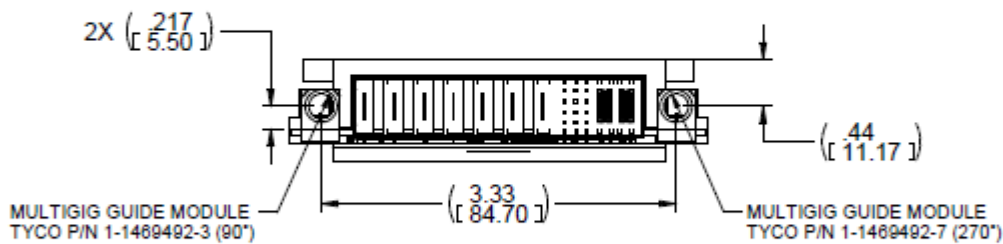

## NOTES :

1. WORKMANSHIP SHALL BE MIL-STD-454, REQT. 9
2. DRILL, TAP & COUNTERSINK PER MS 33537
3. MAIN BODY AND COVERS
  - 3.1 MTL. ALUMINIUM ALLOY 6061-T651& AL 5052-H32
  - 3.2 FINISH: CONVERSION COATING PER MIL -C-5541 TYPE 1, CL 1A
4. EJECTOR/INJECTOR
  - 4.1 MTL. ALUMINIUM ALLOY 6061-T651
  - 4.2 FINISH: BLACK ANODIZE PER MIL-A-8625, TYP II, CLASS 2

**A**

# PS SERIES: PSVA3UTPU125P800-X

## Standard Configurations

Part number	Input		VS1		3.3V_Aux	
	Voltage range	Frequency	Voltage	Current	Voltage	Current
PSVA3UTPU125P800-0	3-phase, 100 to 125 V <sub>AC</sub>	400 Hz	28 V <sub>DC</sub>	30 A	3.3 V <sub>DC</sub>	0.4 A

*Note: Specifications are subject to change without prior notice by the manufacturer.*

