

## PS SERIES PSVHP140 VPX PS ENERGY STORAGE MODULE

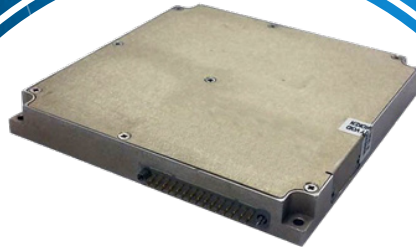

- No external cap required
- Holds at least 140 W for 50 MS

- Miniature size
- High efficiency
- Wide input range
- Fixed switching frequency
- External Synchronization ( $250 \pm 10$  kHz)
- EMI filters included
- Indication for Input failure and Hold-Up activation
- Internal capacitor stores at least 7 Joules.
- External capacitor connection option for additional Hold Up time.
- Operates together with Amphenol Source standard DC/DC converter modules. *Consult factory for applications.*

**Environmental Conditions** Meets or exceeds MIL-STD-810C Temperature:

Operating:  $-55^{\circ}\text{C}$  to  $+85^{\circ}\text{C}$  (baseplate) Storage:  $-55^{\circ}\text{C}$  to  $+125^{\circ}\text{C}$

Vibration level: Up to 9 g rms.

*Consult factory if higher levels required.*

### **Reliability**

Minimum 150,000 hours.  
Calculated IAW MIL-STD-217F Notice  
2 at  $+85^{\circ}\text{C}$  baseplate, Ground Fix conditions.

### **DC INPUT**

Normal input voltage range: 18 to 48 V<sub>DC</sub>

Input transient protection:

No damage due to abnormal voltage surge IAW MIL-STD-1275A (100 V for 50 ms) and IAW MIL-STD-704A (80 V for 0.1 s)

Steady-state quiescent current:

< 50 mA EMC:

Designed to meet MIL-STD-461F\*  
CE101, CE102, CS101, CS114, CS115,  
CS116, RE101, RE102, RS101, RS103

Isolation:

Input to Case: 200 V<sub>DC</sub>

### **DC OUTPUT**

Normal input voltage range:

Following input and when power off the output voltage is 50VDC and decreasing.

Output current capacity:

12 A max.

*Consult factory if higher current required.*

Isolation:

Output to Case: 200 V<sub>DC</sub>

**\*EMC compliance achieved when tested with 5 H LISNs, shielded harness and static resistive load.**

## Markets & Applications



Military, Ruggedized



Telecom, Industrial Hold-up module

## Connection Diagram

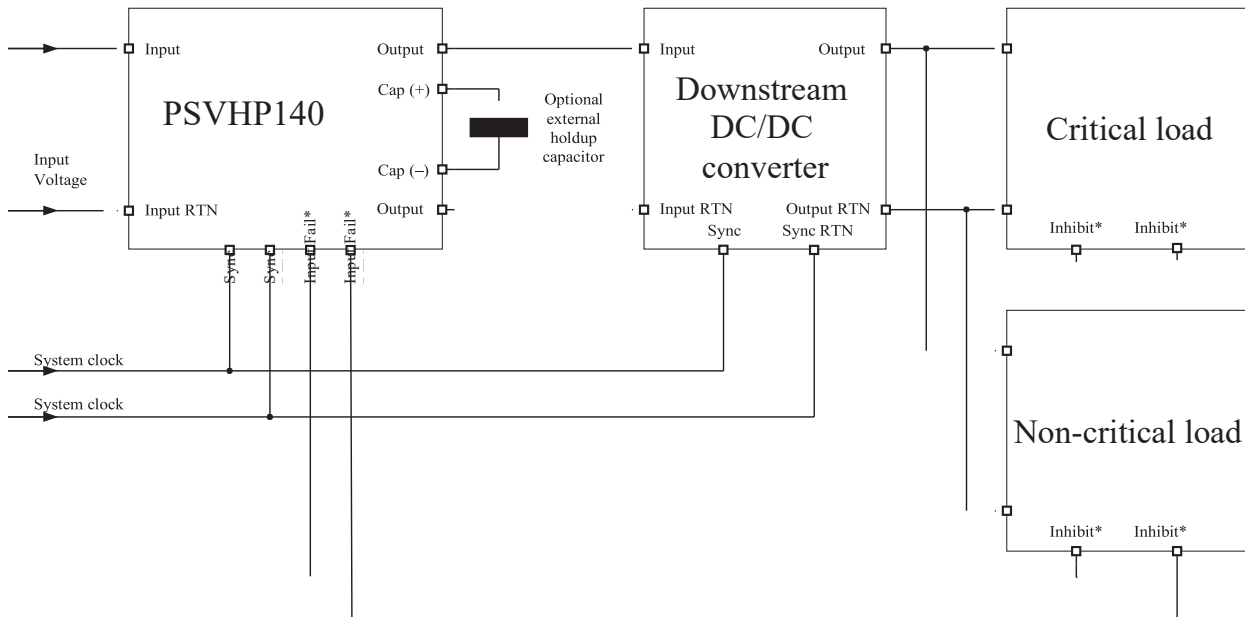

## Block Diagram

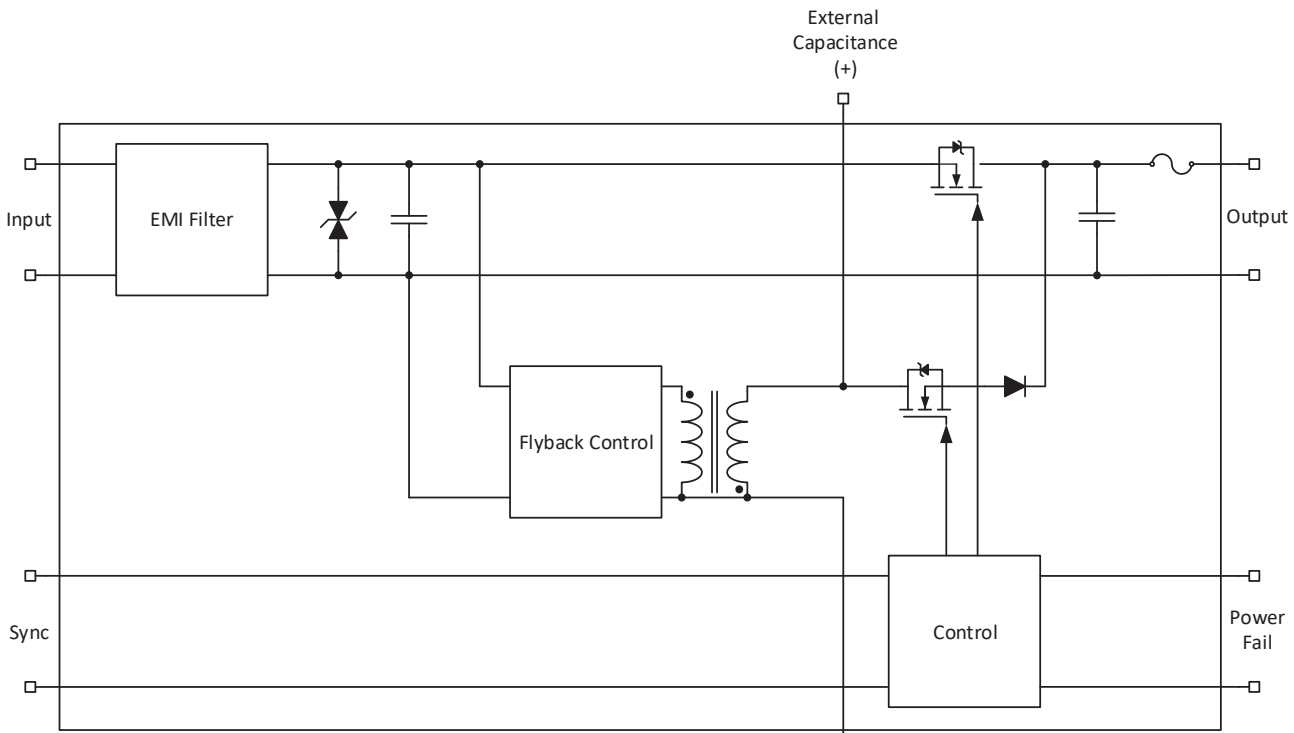

### *Description of Operation*

This energy storage module should be installed in front of a wide input voltage range DC/DC converter, and not as a standalone. The module provides input voltage for the downstream DC/DC converter when a power failure occurs, such that if the input power returns to normal range within a specific period of time, the downstream DC/DC converter (and therefore the load) can't tell that a power failure had happened.

This unit is designed to be used with most of Amphenol Source's DC/DC converters and DC/AC inverters (consult factory for applicability to specific models).

During normal operation, an internal converter charges the internal capacitors (and external, if connected) to 48 to 52 V.

In case the input voltage falls below 16 V, the input is disconnected from the output via an internal MOSFET switch, and the caps are connected to the output pins through another internal MOSFET switch. The caps are then naturally discharged into the cascaded power supply, until the caps have been depleted to a level that the voltage is below the cascaded power supply's under-voltage lockout threshold (for Amphenol Source's converter this value is usually between 16V to 18V).

When input power returns (it can happen during cap discharge or after complete loss of power), the MOSFET switches disconnect the output from the caps, reconnect the input to the output, and the internal converter recharges the caps, preparing them for the next power failure.

# PS SERIES: PSVHP140

## Pin Assignment

**Connector type:** M55302/61-A30 or eq.

**Mates with:** M55302/66-30H (22 AWG crimp removable contacts) or M55302/62-A30M (solder cup contacts) or eq.

Pin No.	Function	P	
1	INPUT FAIL *	+	●
2	INPUT FAIL * RTN	-	●
3	EXT CAP RTN	-	●
4	EXT CAP	+	●
5	OUTPUT	+	●
6	OUTPUT	+	●
7	OUTPUT	+	●
8	INPUT	+	●
9	INPUT	+	●
10	INPUT	+	●
11	INPUT RTN	-	●
12	INPUT RTN	-	●
13	INPUT RTN	-	●
14	OUTPUT RTN	-	●
15	OUTPUT RTN	-	●

Pin No.	Function	P	
16	SYNC	+	○
17	SYNC RTN	-	●
18	EXT CAP RTN	-	●
19	EXT CAP	+	●
20	OUTPUT	+	●
21	OUTPUT	+	●
22	OUTPUT	+	●
23	INPUT	+	●
24	INPUT	+	●
25	INPUT	+	●
26	INPUT RTN	-	●
27	INPUT RTN	-	●
28	OUTPUT RTN	-	●
29	OUTPUT RTN	-	●
30	OUTPUT RTN	-	●

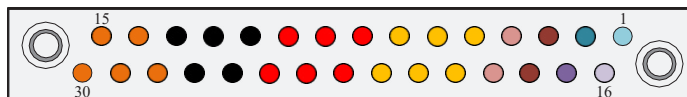

## *Signals Description*

### **INPUT FAIL\*** (pin 1)

This signal is used to communicate an input voltage failure condition.  
Signal type is open collector of a PMBT2222 bipolar transistor.

#### **FAIL:**

Condition: Input voltage was within normal range and dropped below  $17.6 \pm 0.5$  V.

Result: The pin will be pulled down to **INPUT FAIL RTN** pin through a  $6.2 \Omega$  resistor.

#### **NORMAL:**

Condition: Input voltage returned to above  $17.6 \pm 0.5$  V.

Result: The pin will go into high impedance mode (OPEN).

If this function is not required, leave this pin unconnected.

This signal is referenced to **INPUT FAIL RTN** (pin 2)

### **SYNC** (pin 16)

**This signal is used to synchronize the internal switching converter's frequency to external clock.**

Valid external clock frequency is  $250 \text{ kHz} \pm 10 \text{ kHz}$ ; Valid duty cycle:  $50 \pm 10\%$

When no external clock is present, the power supply uses its internal clock.

If this function is not required, leave pin unconnected.

This signal is referenced to **SYNC RTN** (pin 17)

### **EXT CAP** (pins 4 and 19)

**Connect these pins to external capacitor for increased holdup time.**

Unless specified otherwise in the specific variant's catalog page, the voltage at these pins is set to  $51 \text{ V}_{\text{DC}}$ .

These pins are referenced to **EXT CAP RTN** (pins 3 and 18).

### **INPUT** (pins 8, 9, 10, 23, 24 and 25)

Connect these pins to the input power source.

These pins are referenced to **INPUT RTN** (11, 12, 13, 26 and 27) and **OUTPUT RTN** (pins 14, 15, 28, 29 and 30)

### **OUTPUT** (pins 8, 9, 10, 23, 24 and 25)

Connect these pins to the downstream Milpower Source DC/DC converter.

These pins are referenced to **OUTPUT RTN** (pins 14, 15, 28, 29 and 30) and **INPUT RTN** (11, 12, 13, 26 and 27)

## Outline Drawing

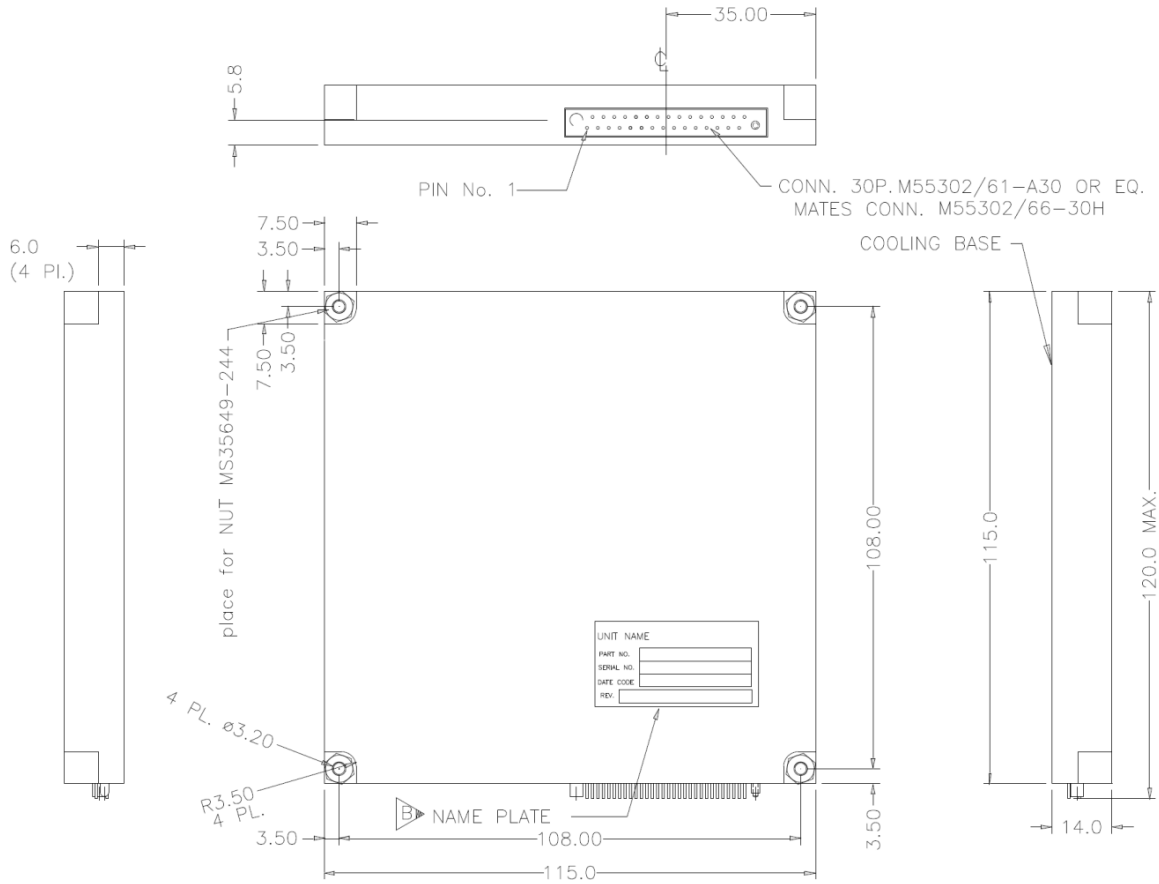

\* Connector: M55302/61-A30 or eq. (mates with M55302/62-A30M or eq.)

## Notes

1. Dimensions are in inches [mm]
2. Tolerance is:  
.XX  $\pm 0.01$  in  
.XXX  $\pm 0.005$  in
3. Weight: Approx. 8.8 oz (250 g)

**Note: Specifications are subject to change without prior notice by the manufacturer**