

Amphenol

RJ-Switch

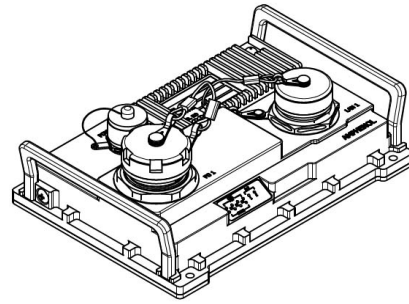

IP67/68 rugged Ethernet Media converter RESGMC 1S 100 RJF 1TACB OD DC - User Manual -

Contents

Section 1	General Information	Page 3
Section 2	Hardware	Page 4
Section 3	Installation	Page 5
Section 4	Wiring	Page 6
Section 5	Features Overview	Page 10
Section 6	Service Information	Page 12

This manual applies to the following products:

- **RESGMC 1S 100 RJF 1TACB OD DC**
Rugged IP67/68 Ethernet Media converter 10/100/1000 Mbit/s,
Singlemode 9/125 μ m fiber optics, TACBeam connector

Revision	Date	Modifications
1.0	February, 10 th , 2020	Initial document

Amphenol Statement of Limited Warranty:

Products shall benefit from a legal guarantee of one year following the date of delivery in accordance with the terms and conditions indicated hereunder.

In all instances, Seller's guarantee shall be limited to free replacement, in identical quantities, of the Product acknowledged as defective by Seller with the exclusion of any compensation or damages and interests other than agreed in a specific contract.

The guarantee is subject that Client notifies Seller of defect immediately following discovery thereof by any written means during the legal guarantee period. Defective Products shall be returned to Seller in accordance with the same procedure as that applicable to Products which do not comply with orders as indicated under article 9 hereinabove.

The following shall be excluded from the guarantees provided by Seller:

- Product defects resulting from inadequate maintenance, or supervision and, more widely, any use which does not comply with written instructions of Seller and indicated in technical notices and/or product specifications, or default in respecting applicable standards or professional customs and uses;
- Product defects resulting from an external cause or any modification or intervention by Client or third party without the prior written consent of Seller;
- The guarantee shall not cover normal wear and tear of Products;
- Product defects resulting generally in whole or in part from damage or accidents attributable to Client or a third party;
- More specifically whether the cover of the switch enclosure have been opened.
- Whether the components have been damaged in transit or have not been stored by the Customer in conditions in accordance with the specification.
- The guarantee shall not cover any defects resulting from instructions given by Client to Seller ;
- Whether the components have been subjected to abuse (mechanical, electrical or thermal) on installation or on use and, in the case of slices/dice, have been subjected to handling or such operations as the welding of connecting wires mounting by soldering or sticking.
- Whether the unfitness or defectiveness of the components has resulted from exceeding the maximum values for usage (temperature limit, maximum voltage, etc.) as defined by the Vendor, or from incorrect choice of application.
- Damages resulting from force majeure, such as this is defined under article 11 of Amphenol Socapex Sales Conditions hereunder, or resulting from any unpredictable event or natural disaster.
- Furthermore, the guarantee shall not cover consequential liability, direct or indirect which may result from the failure of a component supplied by the Vendor.

Client shall retain sole and exclusive liability for the use of Products provided by Seller and the suitability thereof for use.

Client should ensure that its premises and storage conditions are adequate for the due and proper storage of Products and ensure all safety guarantees as stipulated by regulations in force. No guarantee shall be provided by Seller in this regard.

Note: All information in this document is subject to change without notice.

Section 1

General Information

Overview

This manual will help you install and maintain the Amphenol Rugged Media converter. These products are extremely easy to install and operate.

Military applications can now take full advantage of extended Ethernet network using RESGMC 1S 100 RJF 1TACB OD DC media converter.

The installation guide describes how to install and use the hardened Ethernet RESGMC 1S 100 RJF 1TACB OD DC Military Rugged Media converter. Capable of operating at extreme temperature of -35°C to +75°C and meet the toughest industrial and military environments such as MIL-STD-810F, MIL-STD-461E up to the highest levels.

The unit has been especially hardened to improve ingress, impact, and shock/vibration protection, as well as eliminate all moving parts through passive cooling, and interface through sealed MIL-DTL-38999 series III and TACBEAM connectors.

Performance Specifications

These general specifications apply to these equipments. Refer to Section 6 for complete technical specifications.

Ports	1x copper 10/100/1000BaseT(X) 1x optical fiber 100BaseFX , Singlemode 9/125µm
Voltage	24Vdc Nominal (18-36 VDC) Power Consumption: 2.8W typical
MIL standards	MIL-STD-461E, MIL-STD-810G
Electromagnetic	MIL-STD-461E Electromagnetic compatibility CE-102, CS-114, CS-115, CS-116, RE-102, RS-103
Operating Temp.	-35°C to +75°C (-31°F to +167°F) – Cold Start-Up
Waterproof	IP67/68

Section 2

Hardware

Overview

The media converter can be mounted directly to a flat surface or to a wall. Refer to the mechanical drawing below. Its high protected enclosure makes it able to withstand immersion (IP67/68 rating).

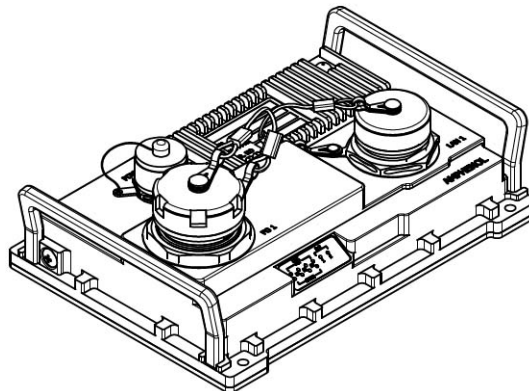

Figure 1 : RESGMC 1S 100 RJF 1TACB OD DC

LED indicators

The following describes the front panel, and LED indicators of the RESGMC 1S 100 RJF 1TACB OD DC .



Power LED indicator



Ports LED indicators

POWER Indicator

The Single LED indicator on the front panel shows the operative status of the media converter.

Once the LED is turned on, the media converter is powered and ready-for-use.

This LED will be ON solid green when proper power has been applied to the unit.

Ports LED Indicators

Each Ethernet port has 2 LEDs indicators:

- LNK / ACT (Link/Activity)
 - Off: There is no link
 - Steady Green: There is a device connected
 - Flashing Green: There is data transmission)
- SPEED (Red – 10Mbps, Orange – 100Mbps, Green 1000Mbps)

Note: once the media converter is powered and the optical links are not connected, the SPEED led of the fiber port(s) is ON solid green.

PoE Indicators - Green for active PSE or PD

Section 3

Installation

Selecting a Site

As with any electronic device, you should place the equipment where it will not be subject to extreme temperatures, humidity, or electromagnetic interference that exceeds the RESGMC 1S 100 RJF 1TACB OD DC's profile. Specifically, the site you select should meet the following requirements:

- The ambient temperature should be between -35 to 75 degrees Celsius.
- The relative humidity is recommended to be less than 95% percent, non-condensing.
- Surrounding electrical devices should not exceed the electromagnetic field (RFC) standards for MIL-STD-461E.

CAPS for unused connectors

The Ethernet media converters are pre-equipped with caps on all ports, including power and Ethernet.

→ **Make sure all connectors are protected with cap or sealed plug to ensure sealing and prevent from deterioration of the contacts.**

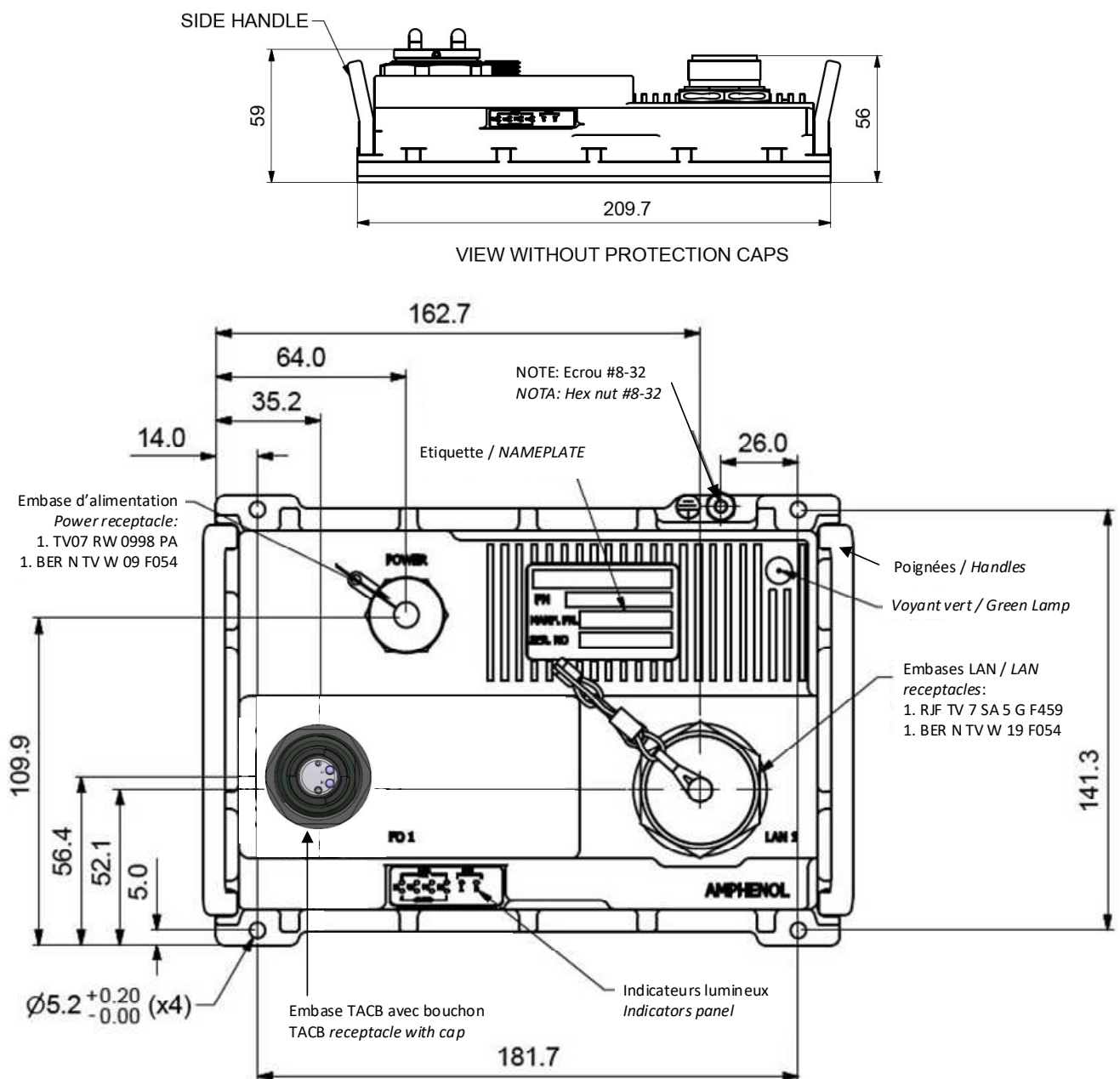

Figure 2 : RESGMC 1S 100 RJF 1TACB OD DC Physical Dimensions

Section 4

Wiring

Overview

These Ethernet media converters provide connections to Ethernet devices in harsh environment. They permit to extend the network on the field over long distances due to fiber optical cordsets.

The Ethernet ports are connected to Ethernet devices such as communication systems, Ethernet I/O, or industrial computers. Electrical isolation is provided on the Ethernet ports for increased reliability.

Please follow normal Ethernet wiring practices when installing these Ethernet media converters.

Power wiring

The Ethernet media converters should be powered using mating plugs and backshells compliant with MIL-DTL-38999 series III. We suggest using hereunder accessories. Another backshell can be used but it must ensure a correct sealing protection.

Power plug part number

Military designation: **JD38999/26WA98SA**

Amphenol designation: **TV06 RW 0998 S A**

This plug is size 9. It is coming with 3 contacts size 20 (7.5 A nominal current).



Power plug wiring

Contact	Signal
A	24 V (+)
B	24 V (-)
C	Not connected

Tooling

The plugs are using crimp contacts.

We suggest using hereunder tooling.

Crimping tools		Amphenol No	Military No
	Crimping tool	809 857	M22520/1-01
	Positioner	809 858	M22520/1-04

Plastic insertion and removal tools	Contact size	Amphenol No	Military no
	20	809 854	M81969/14-10

Backshell

We suggest using TVNSA backshells with corresponding heat shrinks.

These backshells, providing an electrical continuity between cable and connector, ensure a high level of EMI/RFI protection. The sealing is ensured by straight heat shrink molded piece at the rear of the backshell. NSA and SA backshells ensure the shielding by clamping the braid with a screwing system. The free inner ring avoids twisting of the braid during screwing.

Heat-shrinks are molded pieces for harsh environment, fluid resistant (with preinstalled adhesive).

Backshell designation: TVNSA 09 014

Heat shrink designation: 804221

TVNSA backshell dimensions

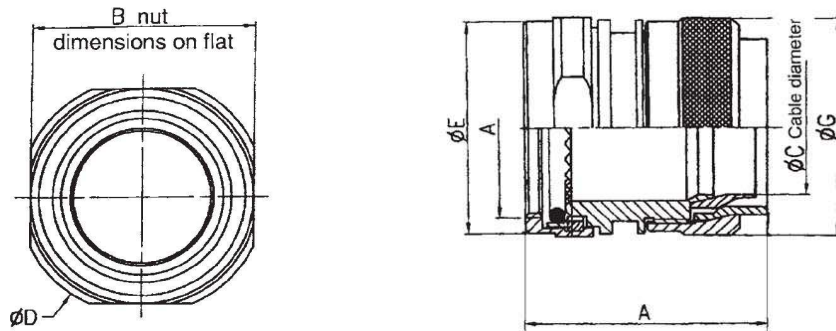

Plug size	A length mm (in)	A thread Metric	B max mm (in)	C max mm (in)	Ø E max mm (in)	Ø G max mm (in)
9 (A)	35.60 (1.402)	M12x1.0 -6H	16.70 (0.658)	6.90 (0.272)	15.62 (0.615)	16.50 (0.650)

TVNSA backshell assembly instruction

1. Prepare the cable for termination process and slide onto the cable the items in the order shown on figure 1.
2. Screw the backshell at the rear of the connector.
3. Fold back the braid on the outer jacket and fix it (figure 2).
4. Install the braid as shown on figures 3 and 4:

Release the braid and cover the backshell (a) and the connector's shell. Slide the first ring (b) over the braid. Fold back the braid on the ring (b) and slide the second ring (c) over the braid and the first ring (b). Screw the last ring (d) at the rear of the backshell. If necessary, fix the extra braid on the outer jacket of the cable. If this installation (double folding of the braid) is not possible, refer to figure 5: Slide the first ring (b).

Release the braid and cover the backshell (a) and the connector's shell. Cut the braid as shown. Slide the second ring (c) over the braid and the first ring (b).

Screw the last ring at the rear of the backshell.

5. Install the heat-shrink molded piece.

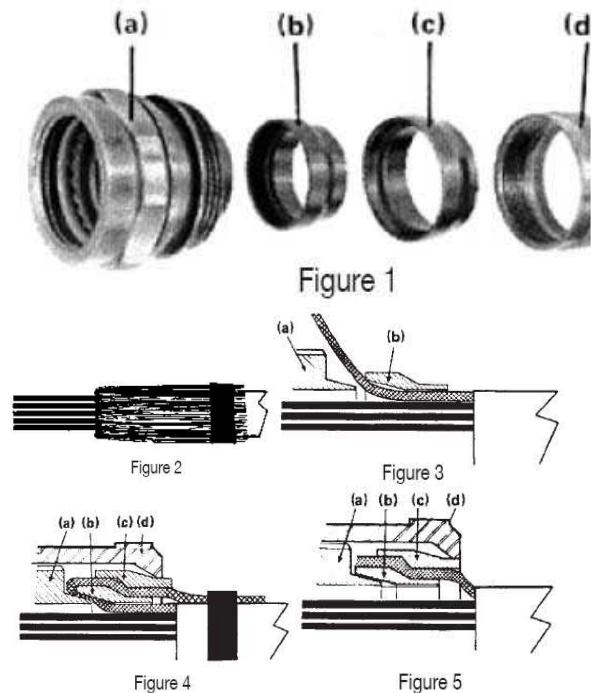

Optical Wiring

The optical link is established using TACBEAM 4 ways connectors. 2 ways are used for data transmission (Rx and Tx).

Consult Amphenol for supplying the correct cordsets and drums.

Ethernet plug

The IP68 rated RJ45 plug is field installable and does not require any special tools. It can be installed over any standard Ethernet patch cable (though you may have to remove the latch cover if it has an over-molded boot). Refer to the diagrams for mechanical and assembly details.

For more details, please consult: <http://www.rifield.com>.

The maximum cable length for 10/100BaseT(x) is typically 100 meters (328 ft.).

Part number of the plug to be used: **RJFTV 6 M G**.

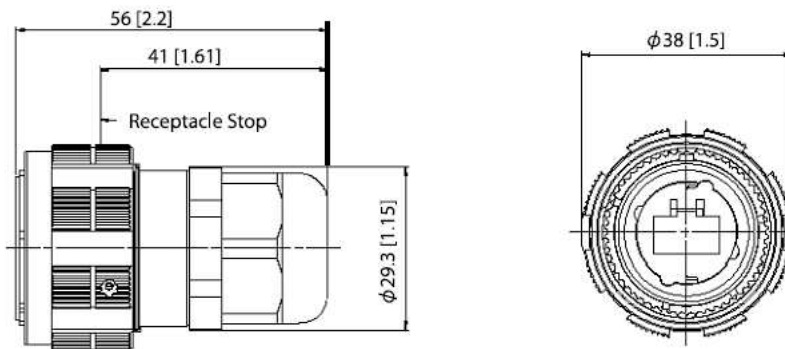

Assembling of the plug.

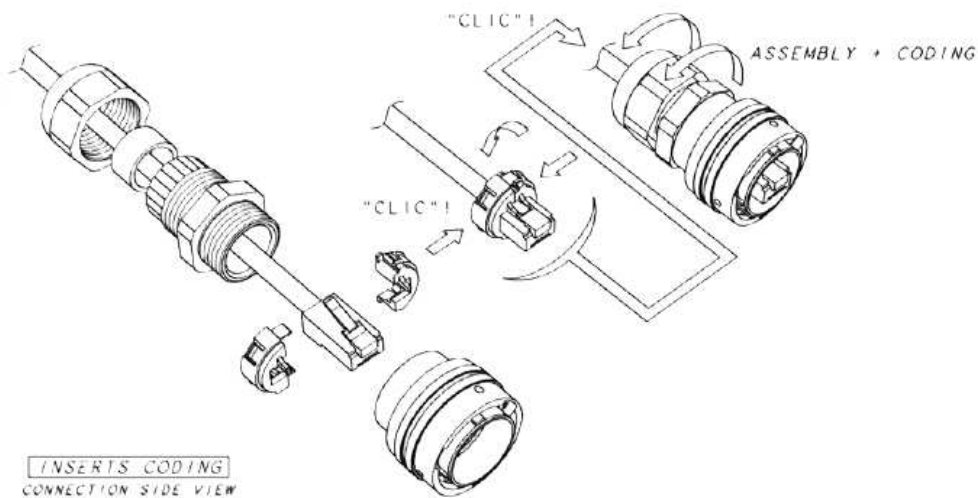

This plug may be assembled with 4 different coding.

Use the **code A** to make your assembly.

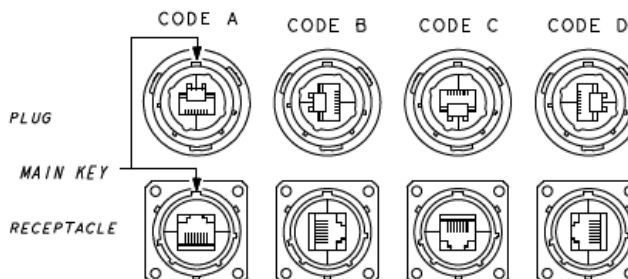

RJ45 Wiring Guidelines

Use data-quality (not voice-quality) twisted pair cable rated category 5e (or better) with standard RJ45 connectors.

Please note that these cables are available as straight-thru or cross-over configurations. Either type can be used because these Ethernet media converters support auto-mdi/mdix-crossover. For reference, the pin-outs of the two cable types are listed below.

Most standard Ethernet cordsets follow one of the TIA-568 guideline given hereafter.

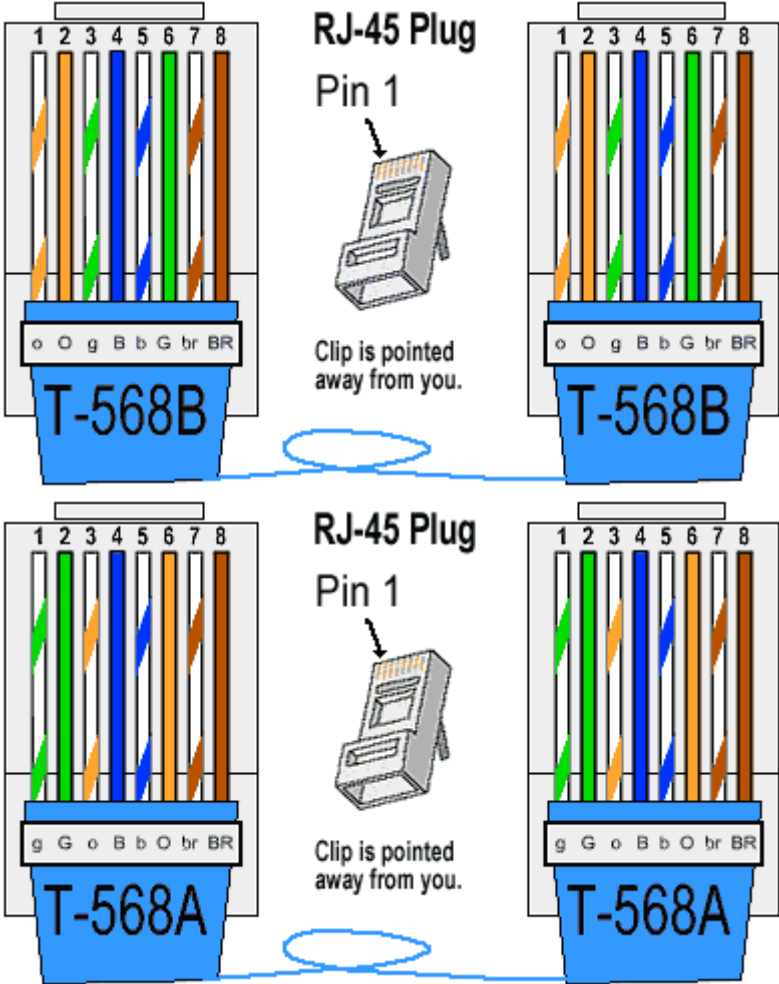

Ethernet Connector Pin Positions

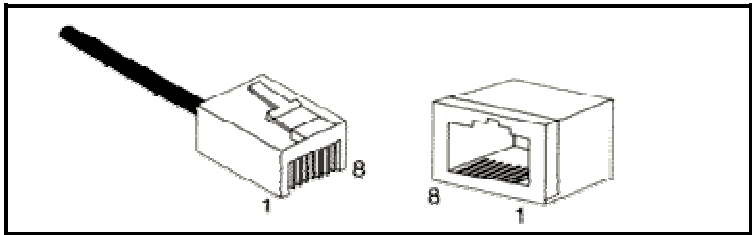

Section 5

Switching Features

Features Overview

Here's a brief explanation of some of the features found in these media converters documented by this manual.

ETHERNET PORTS:

- 1 x 10/100/1000 Ethernet ports
- 1 x 100 Base FX Fiber Optic port, Singlemode 9/125µm fiber

NETWORKING:

- Full wire-speed forwarding rate
- Store-and-forward mechanism
- Auto MDI-II, MDI-X (LAN connector)
- Auto-Negotiation Protocol
- Address Look-Up
- Learning

CONNECTORS:

- LAN : RJ45 7 SA 5G F459
- POWER: TV07RW 0998 PA
- FIBER OPTIC : TACB 77P 2 05 W

CHASSIS:

- Low profile rugged aluminum extrusion
- Conductively cooled w/custom internal heat-sinks
- Ingress protection against sand, dust and moisture
- Painting: Top coat Polyurethane, color Dark Green, two coats 40-50 Microns Thick

STANDARDS:

- MILSTD-1275B: Surge and Spike protection
- MILSTD-461E: Electromagnetic compatibility
- MILSTD-810F: Ground Mobile
- IP67/68

VOLTAGE OPERATION:

- 24 VDC nominal (18-32 VDC)
- Power Consumption: 2.8W Typical
- Exceed MIL-STD-1275B Surge and Spike protection
- Ground: grounding screw provided for connection to system chassis ground

STANDARDS COMPLIANCE:

- IEEE 802.3, 10 Mbps 10BASE-T (Ethernet)
- IEEE 802.3u, 100BASE-TX 100 Mbps (Fast Ethernet)
- IEEE 802.3u, 100Base-FX 100 Mbps fiber optics SINGLEMODE
- IEEE 802.3x Flow Control
- IEEE 802.3ab 1000Base-T (Gigabit Ethernet)

ELECTROMAGNETIC:

- MIL-STD-461E Electromagnetic compatibility
- CE-102, CS-114, CS-115, CS-116, RE-102, RS-103

SHOCK/VIBRATION/HUMIDITY:

- MIL-STD-810F, Random vibration (514.5I), Bench Handling (516.6VI), High Temp.(501.5I,II), Low Temp.(502.5I), Humidity (507.5II), Air Pressure (500.5I,II), Blowing Rain (506.5I), Immersion (512.5I), Salt Atmosphere (509.5I), Blowing Dust (510.5I), Loose Cargo Vibration (514.6II), Wind Analysis
- IP67

PHYSICAL:

- Dimensions: 209 mm (L) x 151 mm (W) x 70 mm (H), including connectors & hardware
- Weight: 1.3 kg

COOLING:

- No Moving Parts. Passive Cooling

OPERATING TEMP:

- -35°C to +75°C (-31°F to +167°F) – Cold Start-Up

STORAGE TEMP:

- -45°C to +85°C (-49°F to +185°F)

Section 6

Maintenance

Service Information

Service Information

These products have been designed in order to operate on the field without any maintenance operation. They come as a complete solution without any modular components that would require change.

You will not need to change any components during all the life of the products.

We sincerely hope that you never experience a problem with any **Amphenol** product. If you do need service, call **Amphenol** at +33(0) 450 89 28 00 and ask for Applications Engineering. A trained specialist will help you to quickly determine the source of the problem. Many problems are easily resolved with a single phone call. If it is necessary to return a unit to us, an RMA (Return Material Authorization) number will be given to you.

Amphenol tracks the flow of returned material with our RMA system to ensure speedy service. You must include this RMA number on the outside of the box so that your return can be processed immediately.

The applications engineer you are speaking with will fill out an RMA request for you. If the unit has a serial number, we will not need detailed financial information. Otherwise, be sure to have your original purchase order number and date purchased available.

We suggest that you give us a repair purchase order number in case the repair is not covered under our warranty. You will not be billed if the repair is covered under warranty.

Please supply us with as many details about the problem as you can. The information you supply will be written on the RMA form and supplied to the repair department before your unit arrives. This helps us to provide you with the best service, in the fastest manner. Normally, repairs are completed in two days. Sometimes difficult problems take a little longer to solve.

We apologize for any inconvenience that the need for repair may cause you. We hope that our rapid service meets your needs. If you have any suggestions to help us improve our service, please give us a call. We appreciate your ideas and will respond to them.

For Your Convenience:

Please fill in the following and keep this manual with your **Amphenol** system for future reference:

P.O. #: _____ Date Purchased: _____

Purchased From: _____

Product Support

To obtain support for Amphenol products:

Visit our website. <http://www.rjswitch.com>

Phone: +33(0) 450 89 28 00

Fax: +33(0) 450 96 29 75

E-mail: <mailto:contact@rjswitch.com>

Mailing Address: Amphenol, Promenade de l'Arve, B.P.29, 74311 Thyez Cedex, France

For more information

You will find all useful information on the RJ-Switch series on the dedicated website:

<http://www.rjswitch.com>